



Chassis Number: F

Order Number: AU-

Project-Number: PR-

Client: ---

File Name: Solo-Rondomat_600_2019-03-25

Last Change: 25.03.2019 13:03

Last Print: 25.03.2019 13:03

\$HeadURL: svn://flsv-eni2/ENI3/Kunden/Biogas%202019/Rondomat/Solo-Rondomat_600_2019-03-25.sch \$

\$LastChangedBy: zaffral \$

\$LastChangedDate: 2019-04-15 17:19:34 +0200 (Mo, 15. Apr 2019) \$

\$LastChangedRevision: 15581 \$

\$Id: Solo-Rondomat_600_2019-03-25.sch 15581 2019-04-15 15:19:34Z zaffral \$

Solo-Rondomat

File name: Solo-Rondomat_600_2019-03-25

Job Number: AU-

Project Nb.: PR-

Article Nb.: 517063

Ser. Nb.:

Solo-Rondomat

Ass.Var:
PCB-Item Nb.: 000000

Blatt 1 von 21



Katalog-Nr.:

Kunde:

Datum 18.03.2019

Bearb. zaffral

Gepr.

Norm

Änderung	Datum	Name	Norm
1			
2			
3			

1

2

3

4

5

6

7

	1	2	3	4	5	6	7
A	Sheet 001: Solo-Rondomat						
	Sheet 002: Index						
	Sheet 003: cable colours						
	Sheet 004: overview motors						
B	Sheet 005: electric feed / heater						
	Sheet 006: voltage distribution 24V						
	Sheet 007: motors						
	Sheet 008: safety relay						
	Sheet 009: control outputs						
C	Sheet 010: disturbances						
	Sheet 011: current measurement						
	Sheet 012: current measurement						
	Sheet 013: external signals						
	Sheet 014: external inputs						
D	Sheet 015: CAN-BUS / external display / radio						
	Sheet 016: touch panel						
	Sheet 017: mechanical parts						
	Sheet 018: mechanical parts						
	Sheet 019: part list						
E	Sheet 020: part list						
	Sheet 021: part list						
F							
G							
H							

- Sheet 001: Solo-Rondomat
- Sheet 002: Index
- Sheet 003: cable colours
- Sheet 004: overview motors
- Sheet 005: electric feed / heater
- Sheet 006: voltage distribution 24V
- Sheet 007: motors
- Sheet 008: safety relay
- Sheet 009: control outputs
- Sheet 010: disturbances
- Sheet 011: current measurement
- Sheet 012: current measurement
- Sheet 013: external signals
- Sheet 014: external inputs
- Sheet 015: CAN-BUS / external display / radio
- Sheet 016: touch panel
- Sheet 017: mechanical parts
- Sheet 018: mechanical parts
- Sheet 019: part list
- Sheet 020: part list
- Sheet 021: part list

Index

Katalog-Nr.:		File name:	Solo-Rondomat_600_2019-03-25	
Kunde:		Job Number:	AU-	Solo-Rondomat
---		Project Nb.:	PR-	
		Article Nb.:	517063	Ass.Var:
				Blatt 2 von 21

Änderung	Datum	Name	Norm
			Datum 18.03.2019
			Bearb. zaffral
			Gepr.

wiring colours

black	power 400V/230V
red	+24VDC control voltage
dark blue	GND 0VDC control voltage
orange	optional
light blue	neutral conductor
green/yellow	protectiv conductor
purple	emergency-stop circuit +24V
green	control circuit
purple/white	emergency-stop circuit GND

cable colours

Katalog-Nr.:



File name: Solo-Rondomat_600_2019-03-25

Job Number: AU-
 Project Nb.: PR-
 Article Nb.: 517063
 Ser. Nb.:

Solo-Rondomat

Kunde:

Ass.Var:
 PCB-Item Nb.: 000000

Blatt 3 von 21

Anderung	Datum	Name	Norm
		Datum	18.03.2019
		Bearb.	zaffral
		Gepr.	

1

2

3

4

5

6

7

Motor	Function	Power	Current	ref. page
M1	Mixer	11 kW	25 A	/7.2G
M2	conveyor screw 3	5,5 kW	11,5 A	/7.3G
M3	conveyor screw 2	5,5 kW	11,5 A	/7.4G
M4	conveyor screw 1	3,6 kW	7,5 A	/7.5G
M5	additional screw	3,6 kW	7,5 A	/7.6G
Total Power		29.20 kW	63.00 A	

overview motors

Katalog-Nr.:



File name: Solo-Rondomat_600_2019-03-25

Job Number: AU-
 Project Nb.: PR-
 Article Nb.: 517063
 Ser. Nb.:

Solo-Rondomat

Ass.Var:
 PCB-Item Nb.: 000000

Blatt 4 von 21

Änderung	Datum	Name	Norm
			Datum 18.03.2019
			Bearb. zaffral
			Gepr.

Kunde:

1

2

3

4

5

6

7

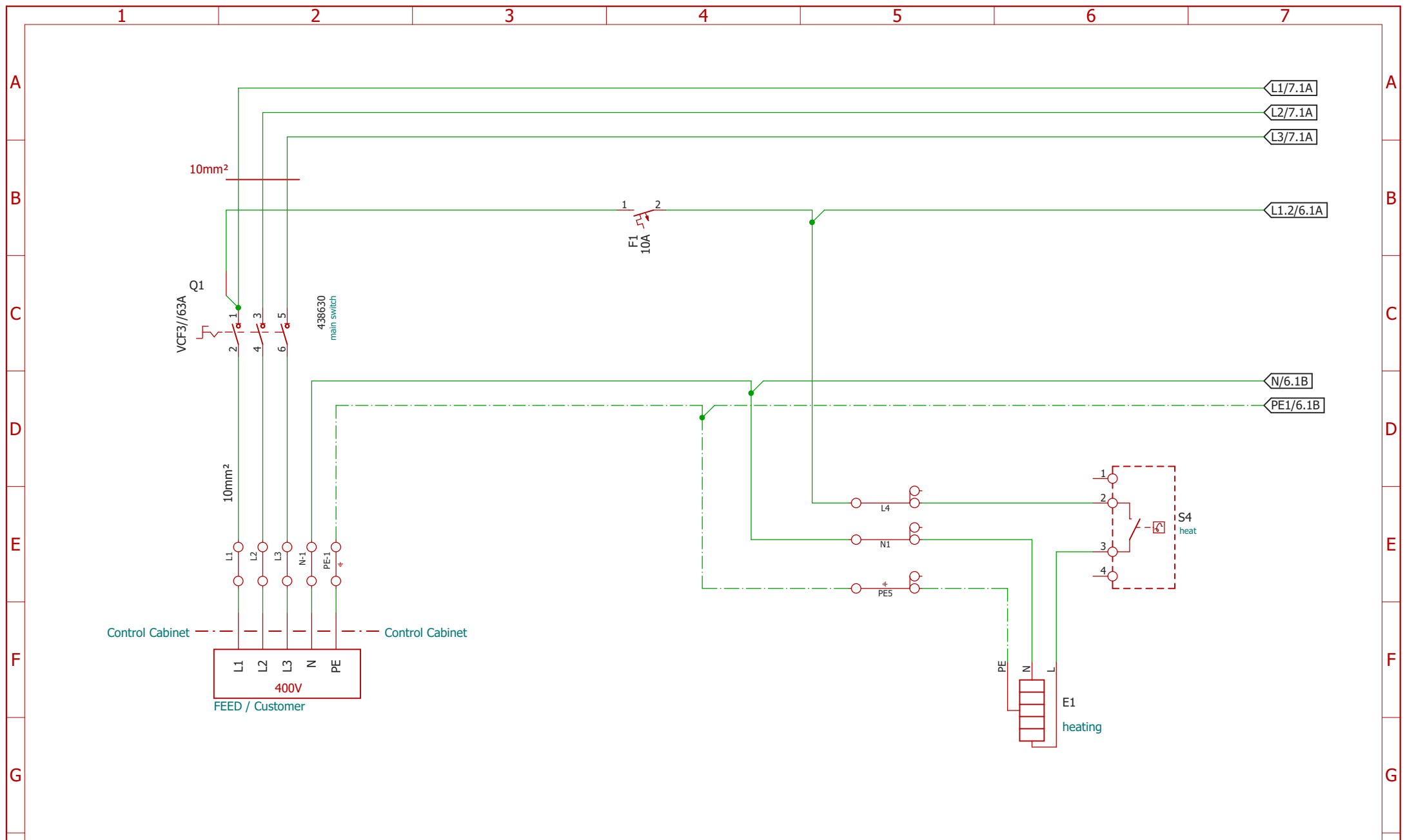

electric feed / heater

File name:	Solo-Rondomat_600_2019-03-25
Job Number:	AU-
Project Nb.:	PR-
Article Nb.:	517063
Ser. Nb.:	

Solo-Rondomat

Ass.Var:
PCB-Item Nb.: 000000

Blatt 5 von 21

Katalog-Nr.:



Kunde: ---

Datum	18.03.2019	
Bearb.	zaffral	
Gepr.		
Norm		
Änderung	Datum	Name

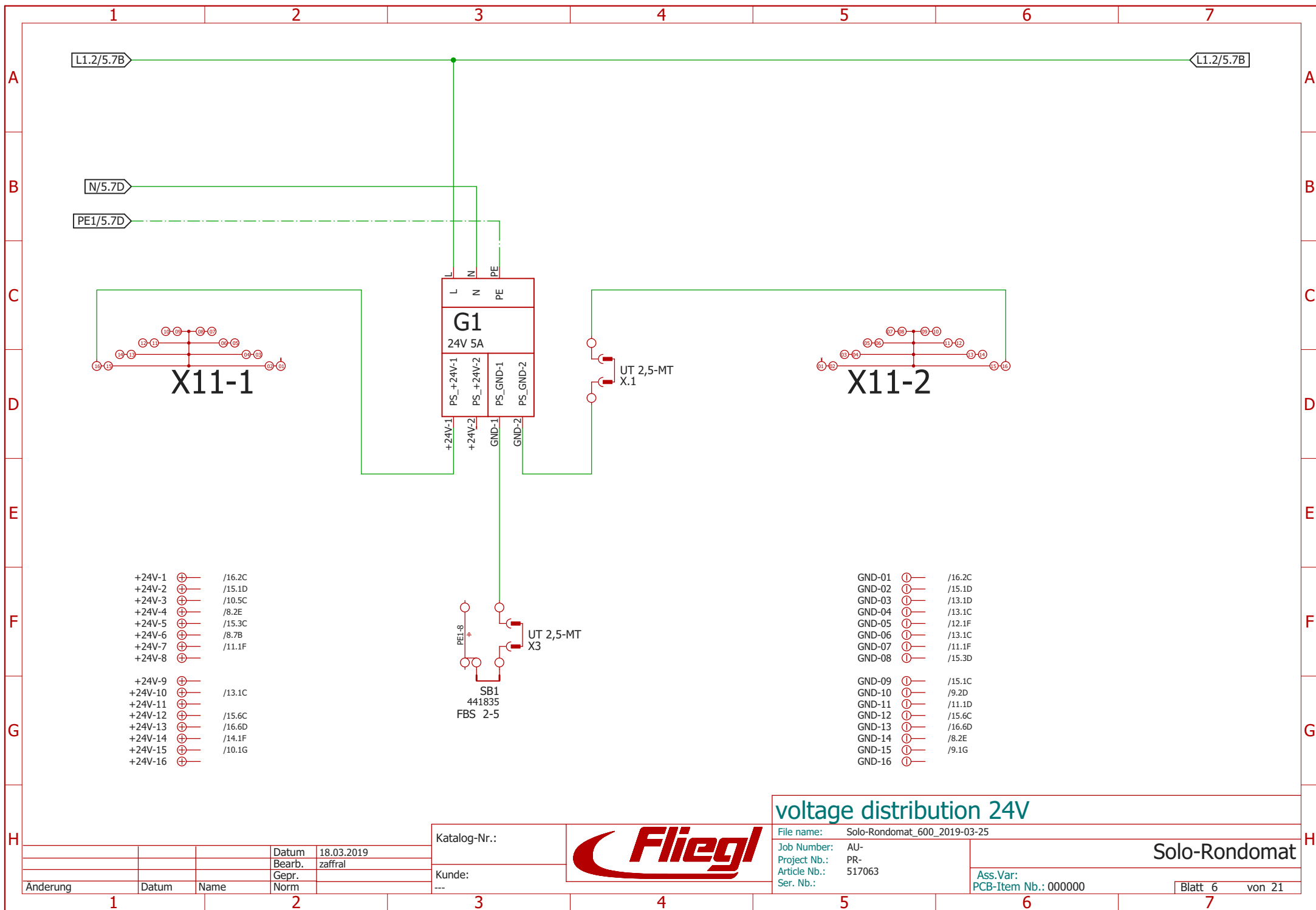

- +24V-1 ⊕ /16.2C
- +24V-2 ⊕ /15.1D
- +24V-3 ⊕ /10.5C
- +24V-4 ⊕ /8.2E
- +24V-5 ⊕ /15.3C
- +24V-6 ⊕ /8.7B
- +24V-7 ⊕ /11.1F
- +24V-8 ⊕
- +24V-9 ⊕
- +24V-10 ⊕ /13.1C
- +24V-11 ⊕
- +24V-12 ⊕ /15.6C
- +24V-13 ⊕ /16.6D
- +24V-14 ⊕ /14.1F
- +24V-15 ⊕ /10.1G
- +24V-16 ⊕

- GND-01 ⊖ /16.2C
- GND-02 ⊖ /15.1D
- GND-03 ⊖ /13.1D
- GND-04 ⊖ /13.1C
- GND-05 ⊖ /12.1F
- GND-06 ⊖ /13.1C
- GND-07 ⊖ /11.1F
- GND-08 ⊖ /15.3D
- GND-09 ⊖ /15.1C
- GND-10 ⊖ /9.2D
- GND-11 ⊖ /11.1D
- GND-12 ⊖ /15.6C
- GND-13 ⊖ /16.6D
- GND-14 ⊖ /8.2E
- GND-15 ⊖ /9.1G
- GND-16 ⊖

voltage distribution 24V

Katalog-Nr.:
 Datum 18.03.2019
 Bearb. zaffral
 Gepr.
 Änderung Datum Name Norm



File name: Solo-Rondomat_600_2019-03-25
 Job Number: AU-
 Project Nb.: PR-
 Article Nb.: 517063
 Ser. Nb.:

Solo-Rondomat
 Ass.Var:
 PCB-Item Nb.: 000000
 Blatt 6 von 21

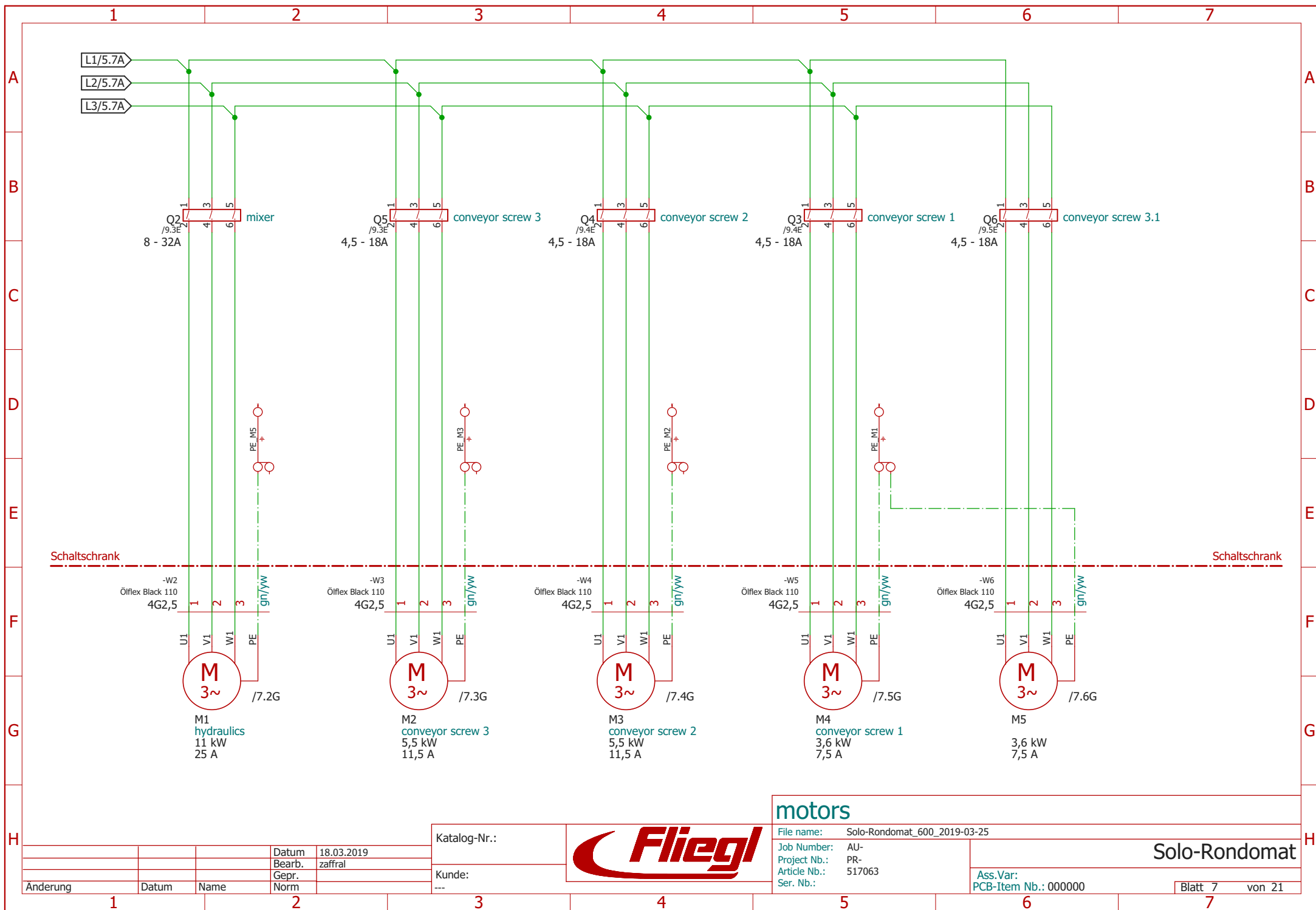

Katalog-Nr.:



motors

File name: Solo-Rondomat_600_2019-03-25
 Job Number: AU-
 Project Nb.: PR-
 Article Nb.: 517063
 Ser. Nb.:

Solo-Rondomat

Ass.Var:
 PCB-Item Nb.: 000000

Datum	18.03.2019
Bearb.	zaffral
Gepr.	
Norm	

Änderung	Datum	Name	Norm
1			

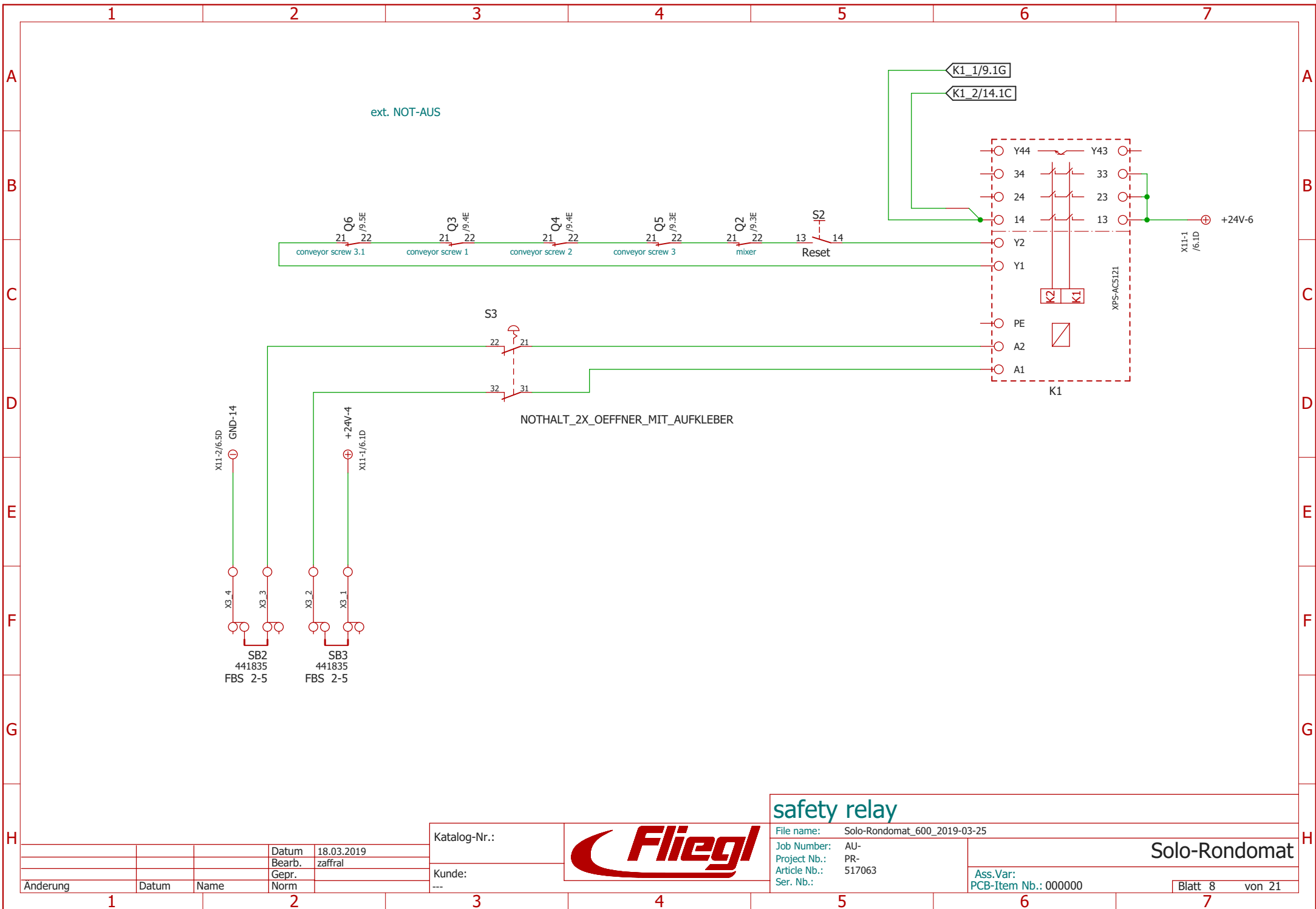

Katalog-Nr.:



safety relay

File name: Solo-Rondomat_600_2019-03-25
 Job Number: AU-
 Project Nb.: PR-
 Article Nb.: 517063
 Ser. Nb.:

Solo-Rondomat

Ass.Var:
 PCB-Item Nb.: 000000

Änderung	Datum	Name	Norm

Datum	18.03.2019
Bearb.	zaffral
Gepr.	

Kunde:

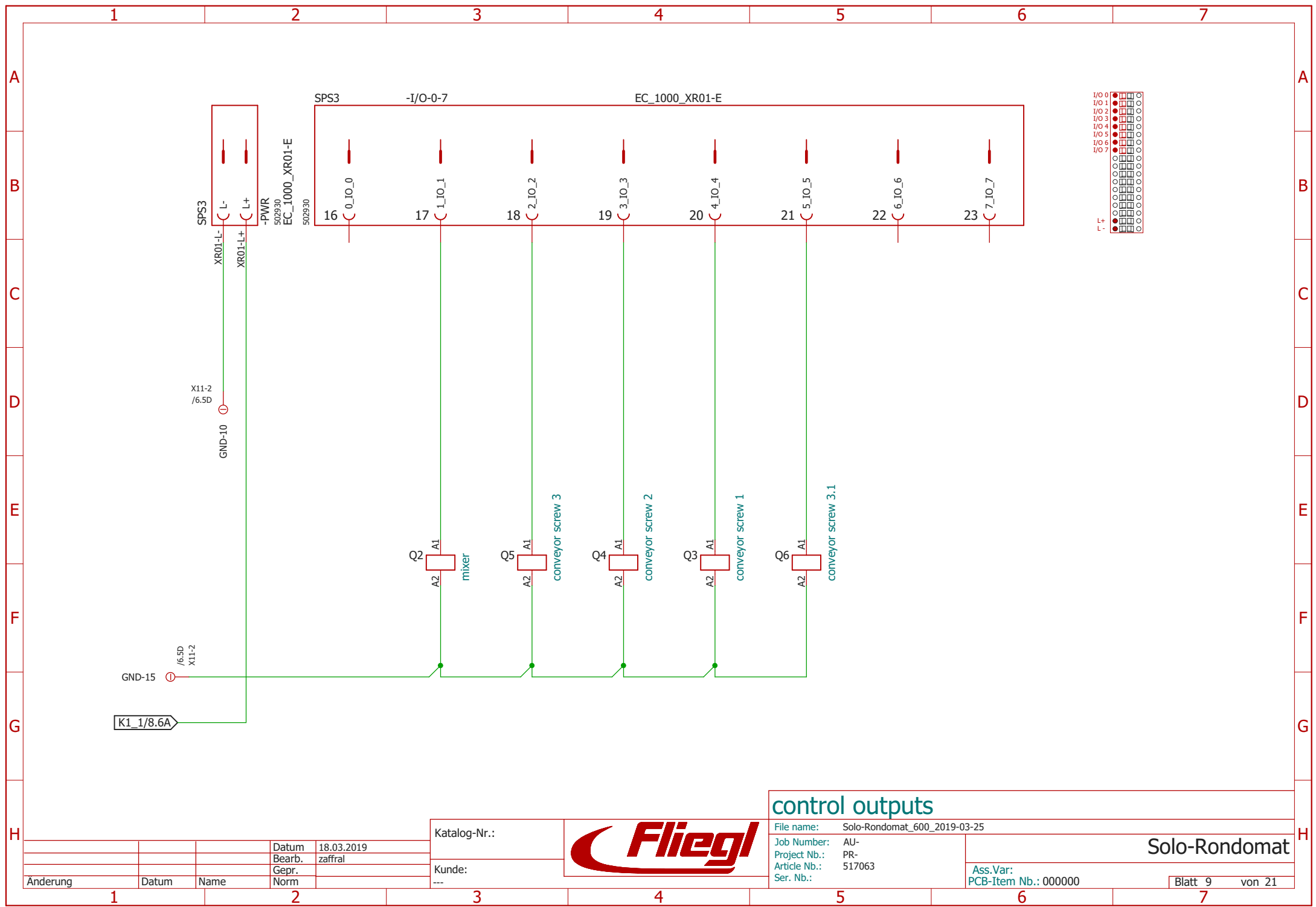

Katalog-Nr.:
Kunde: ---



control outputs

File name: Solo-Rondomat_600_2019-03-25
 Job Number: AU-
 Project Nb.: PR-
 Article Nb.: 517063
 Ser. Nb.:

Solo-Rondomat

Ass.Var:
PCB-Item Nb.: 000000

Änderung	Datum	Name	Norm

Datum 18.03.2019
 Bearb. zaffral
 Gepr.:

SPS3-I-8-15
EC_1000_XR01-E
502930

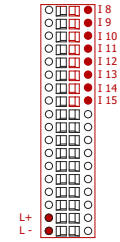
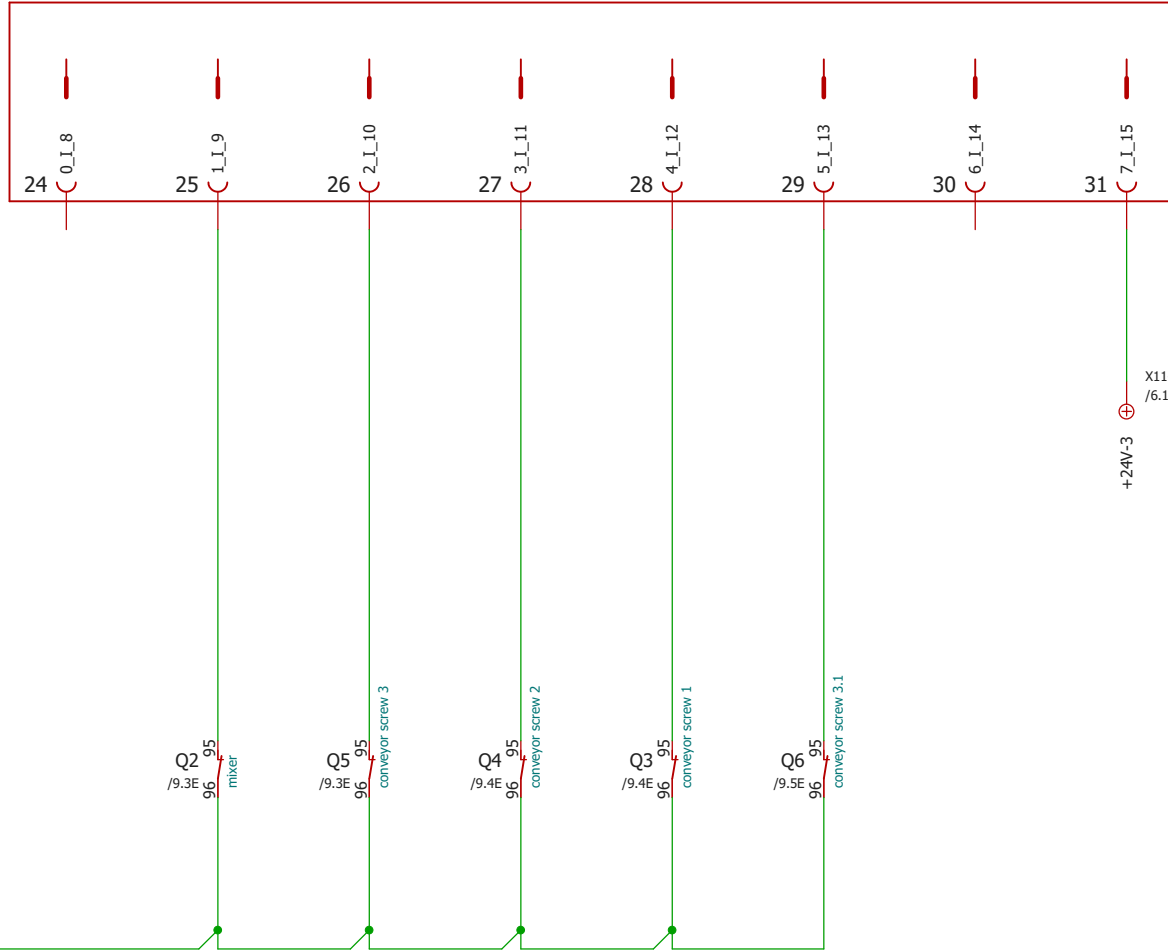

+24V-15 ⊕
/6.1D
X11-1

X11-1
/6.1D
+24V-3 ⊕

Q2 95
/9.3E 96
mixer

Q5 95
/9.3E 96
conveyor screw 3

Q4 95
/9.4E 96
conveyor screw 2

Q3 95
/9.4E 96
conveyor screw 1

Q6 95
/9.5E 96
conveyor screw 3.1

disturbances

Katalog-Nr.:



File name: Solo-Rondomat_600_2019-03-25

Job Number: AU-
Project Nb.: PR-
Article Nb.: 517063
Ser. Nb.:

Solo-Rondomat

Ass.Var:
PCB-Item Nb.: 000000

Blatt 10 von 21

Änderung	Datum	Name	Norm

Datum 18.03.2019
Bearb. zaffral
Gepr.:

Kunde:

1

2

3

4

5

6

7

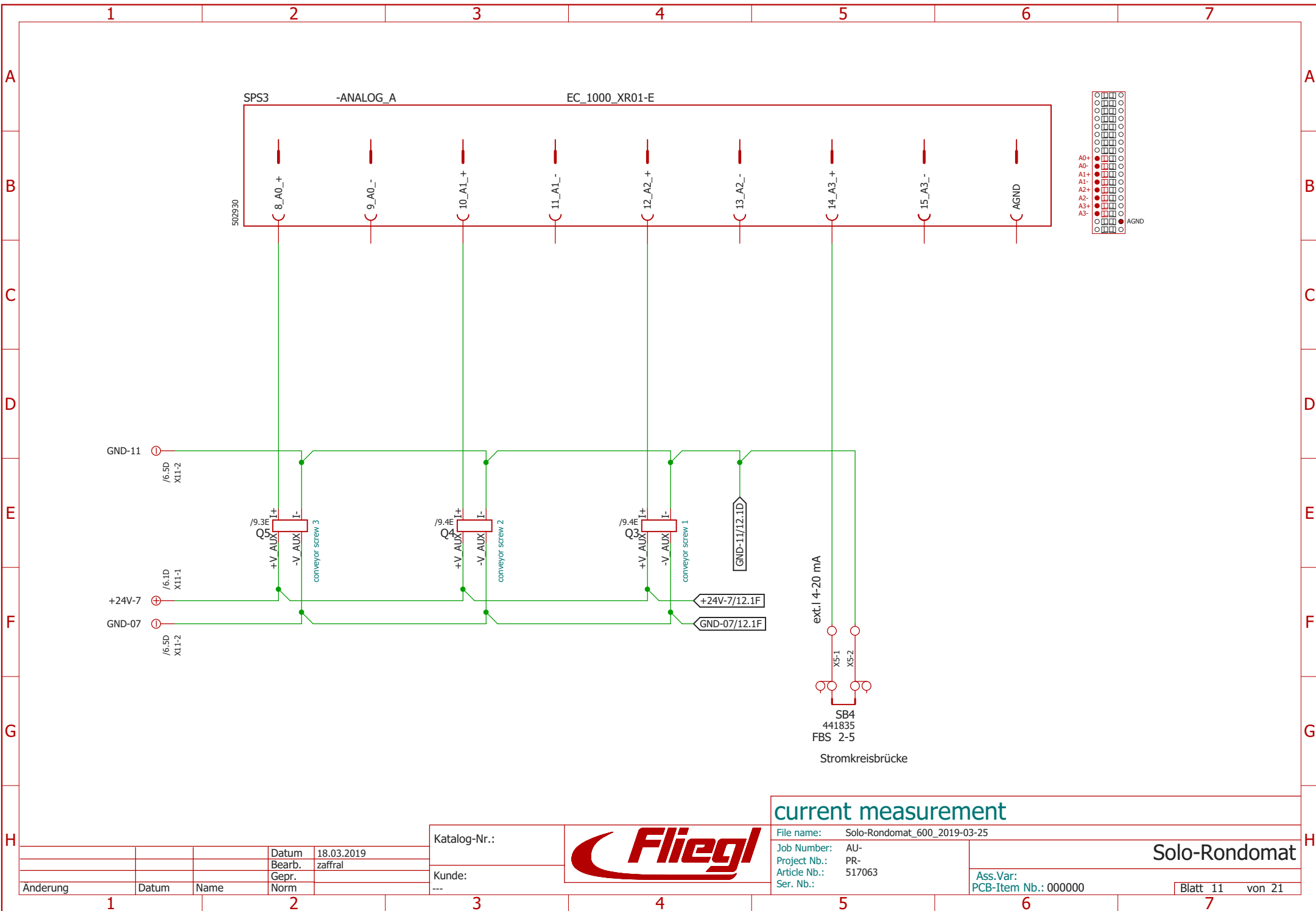

Katalog-Nr.:
 Kunde: ---



current measurement

File name: Solo-Rondomat_600_2019-03-25
 Job Number: AU-
 Project Nb.: PR-
 Article Nb.: 517063
 Ser. Nb.:

Solo-Rondomat

Ass.Var:
 PCB-Item Nb.: 000000

Änderung	Datum	Name	Norm

Datum	18.03.2019
Bearb.	zaffral
Gepr.	

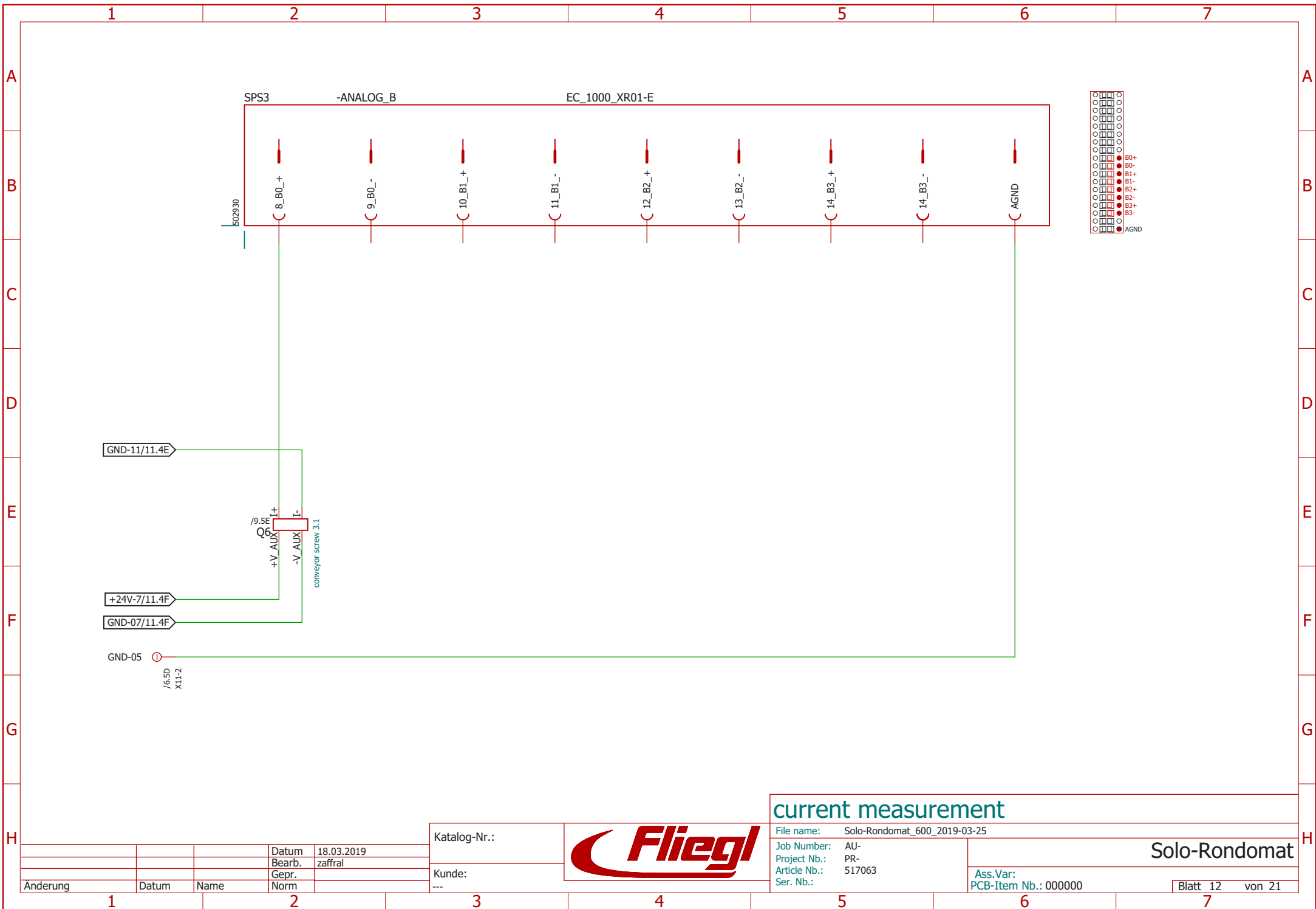

Katalog-Nr.:



current measurement

File name: Solo-Rondomat_600_2019-03-25
 Job Number: AU-
 Project Nb.: PR-
 Article Nb.: 517063
 Ser. Nb.:

Solo-Rondomat

Ass.Var:
 PCB-Item Nb.: 000000

Blatt 12 von 21

Datum	18.03.2019
Bearb.	zaffral
Gepr.	
Norm	

Kunde:

Änderung	Datum	Name	Norm

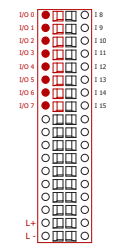
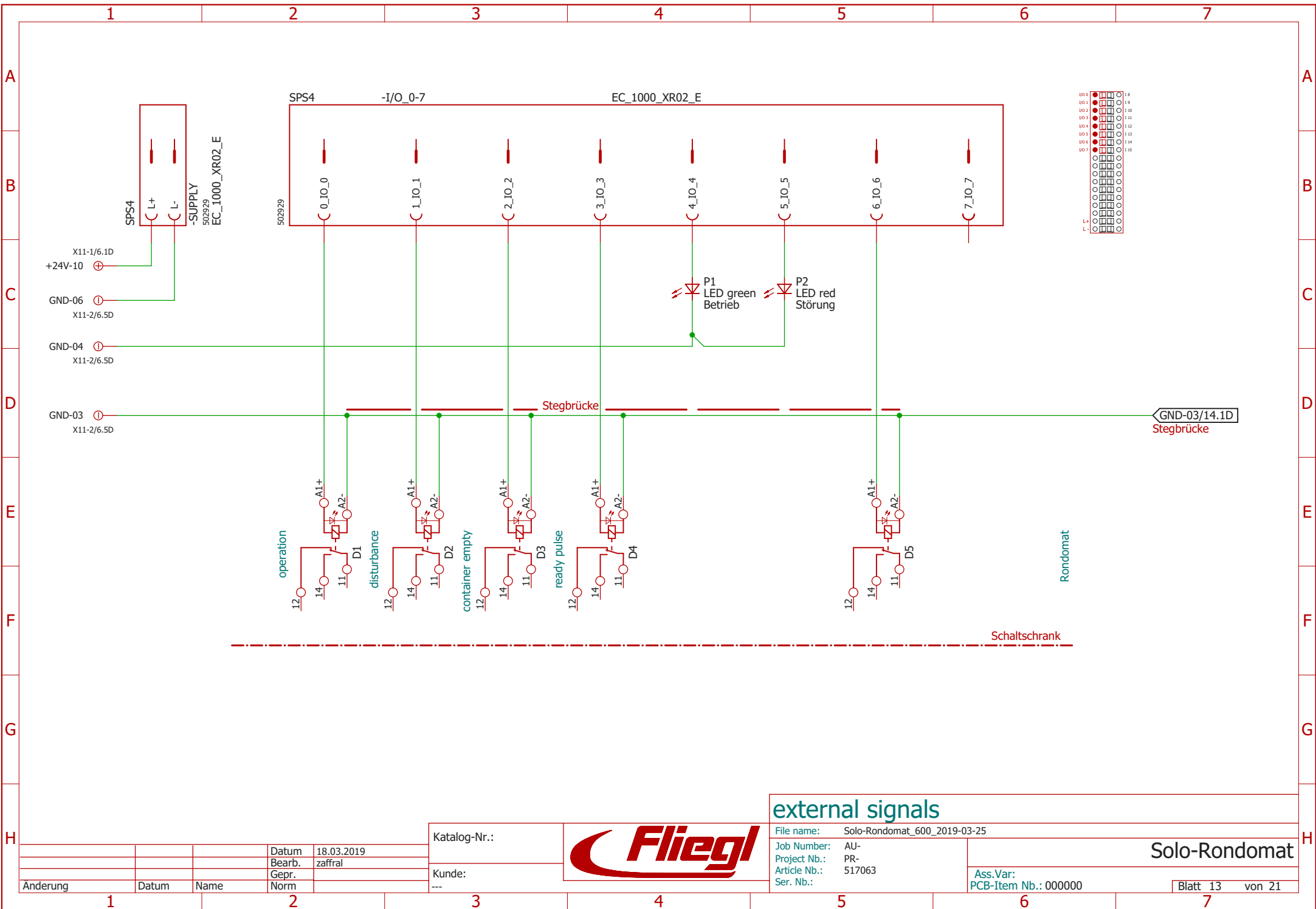

external signals	
File name:	Solo-Rondomat_600_2019-03-25
Job Number:	AU-
Project Nb.:	PR-
Article Nb.:	517063
Ser. Nb.:	
Solo-Rondomat	
Ass.Var:	
PCB-Item Nb.:	000000
Blatt 13 von 21	

Katalog-Nr.:



Kunde: ---

Datum	18.03.2019
Bearb.	zaffral
Gepr.	
Norm	

Änderung	Datum	Name	Norm

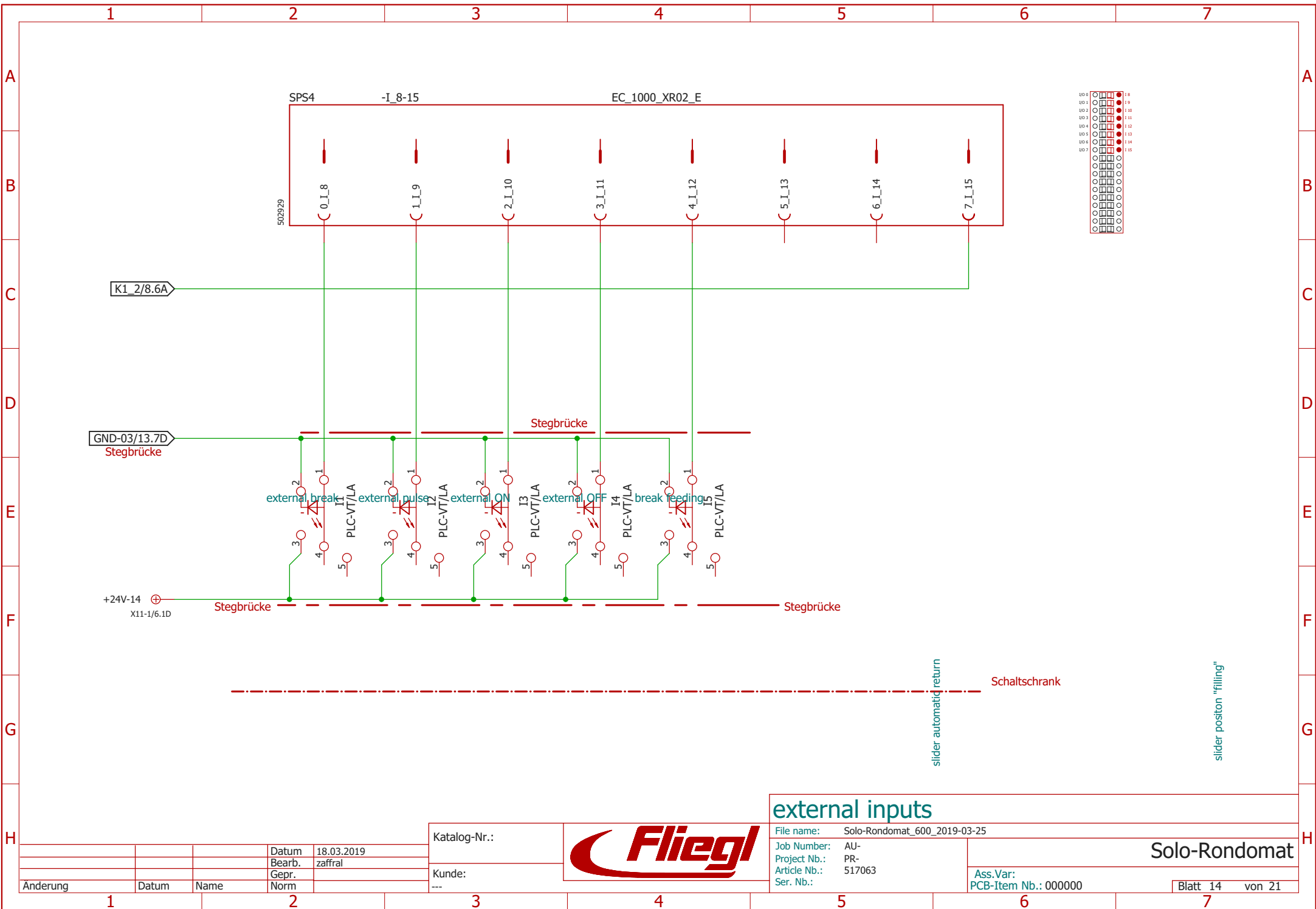

I0.0															
I0.1															
I0.2															
I0.3															
I0.4															
I0.5															
I0.6															
I0.7															
I1.0															
I1.1															
I1.2															
I1.3															
I1.4															
I1.5															

external inputs

File name: Solo-Rondomat_600_2019-03-25
 Job Number: AU-
 Project Nb.: PR-
 Article Nb.: 517063
 Ser. Nb.:

Solo-Rondomat

Ass.Var:
 PCB-Item Nb.: 000000

Katalog-Nr.:
 Kunde: ---



Datum	18.03.2019
Bearb.	zaffral
Gepr.	
Norm	

Änderung	Datum	Name	Norm
1			
2			
3			
4			
5			
6			
7			

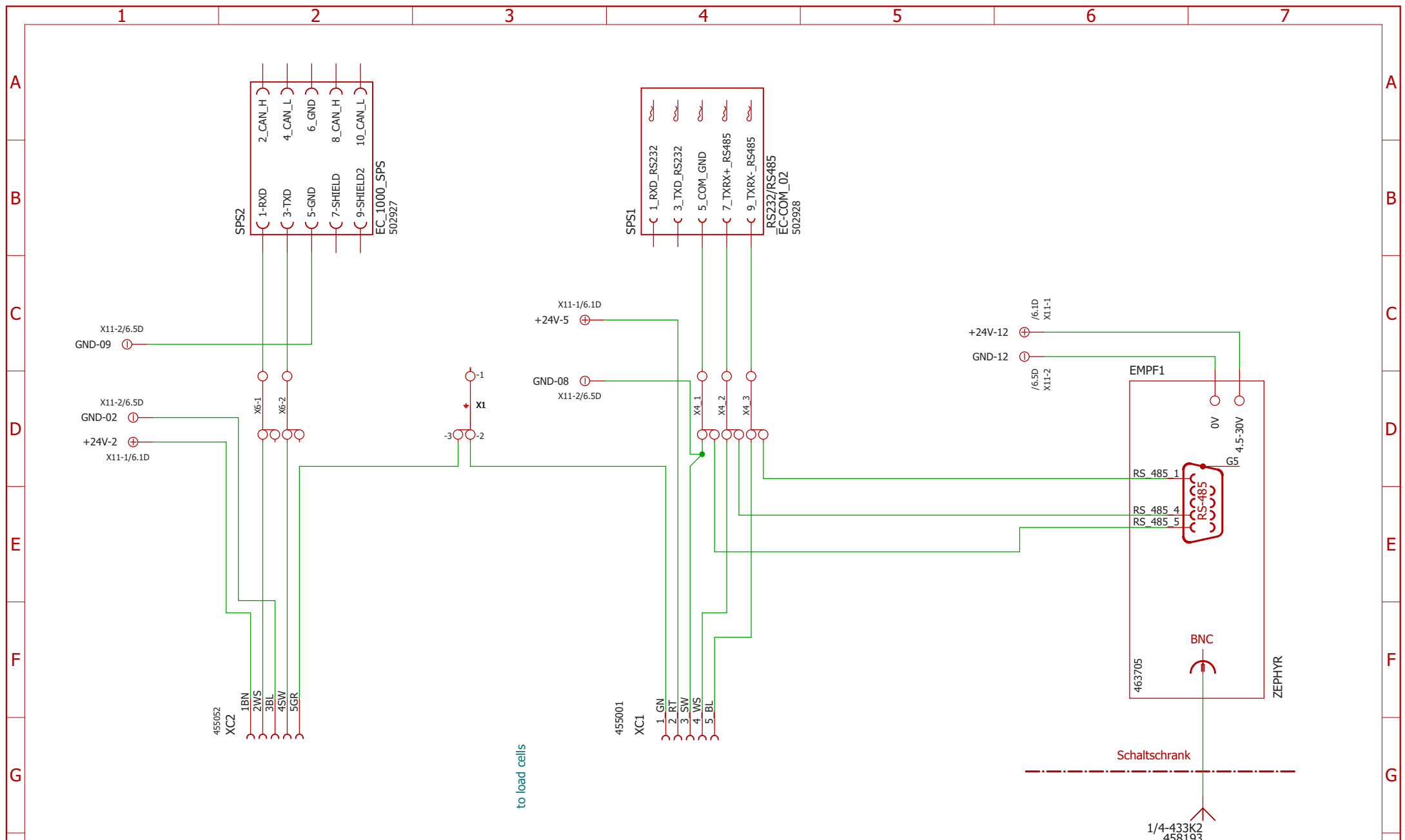

to load cells

CAN-BUS / external display / radio

Katalog-Nr.:	
Datum	18.03.2019
Bearb.	zaffral
Gepr.	
Norm	
Änderung	Datum Name



File name: Solo-Rondomat_600_2019-03-25
 Job Number: AU-
 Project Nb.: PR-
 Article Nb.: 517063
 Ser. Nb.:

Solo-Rondomat

Ass.Var:
 PCB-Item Nb.: 000000
 Blatt 15 von 21

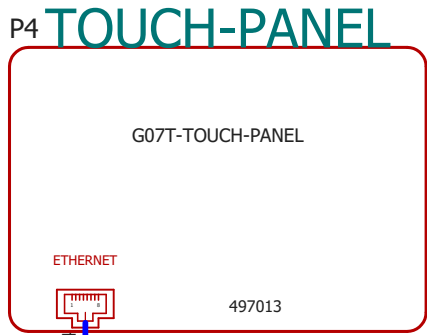
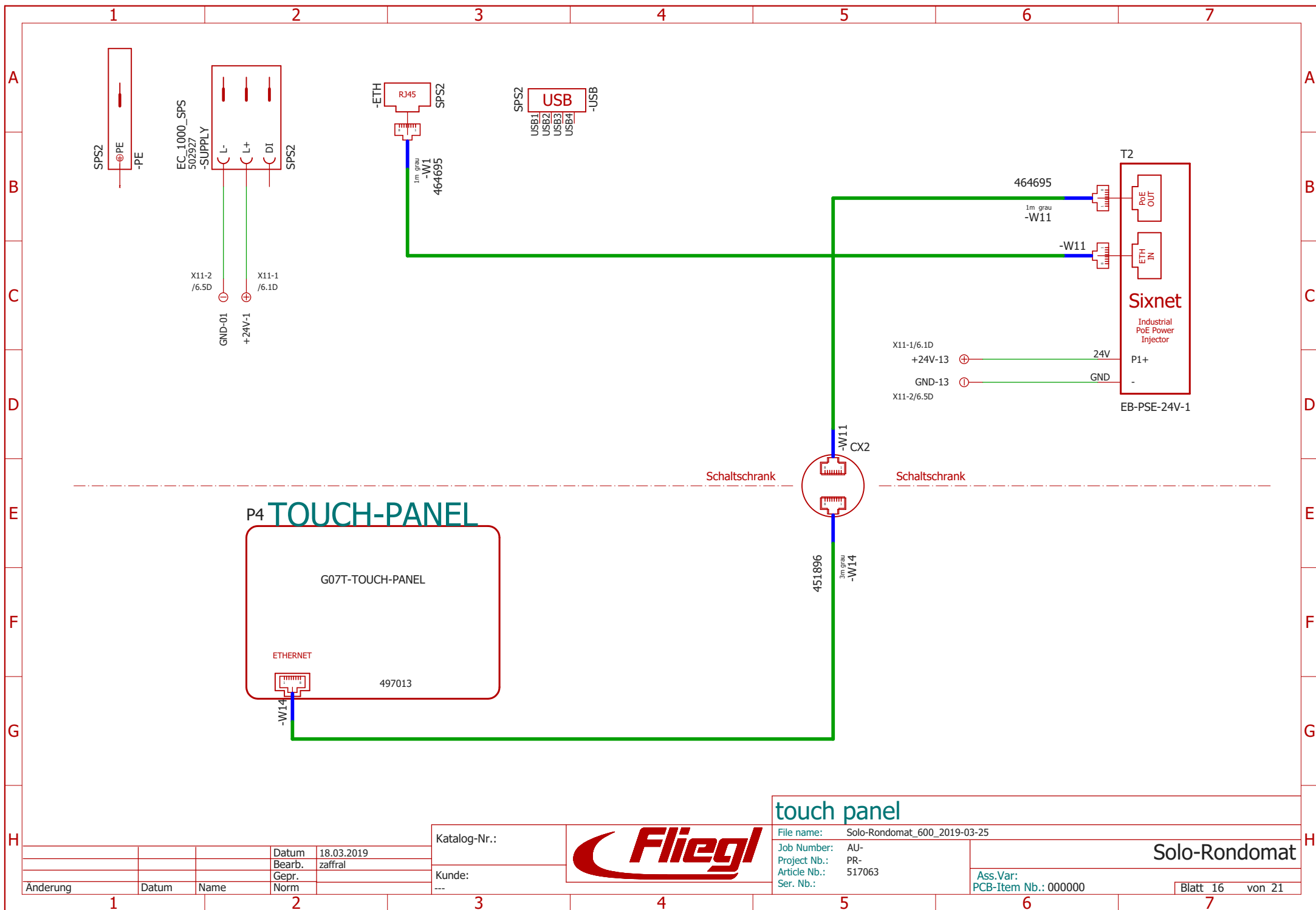

touch panel

Katalog-Nr.:
Kunde: ---





File name: Solo-Rondomat_600_2019-03-25
 Job Number: AU-
 Project Nb.: PR-
 Article Nb.: 517063
 Ser. Nb.:

Solo-Rondomat

Ass.Var:
PCB-Item Nb.: 000000

Änderung	Datum	Name	Norm

Datum 18.03.2019
 Bearb. zaffral
 Gepr.:

	1	2	3	4	5	6	7					
A	SH1	480724	SCHALTSCHRANK 603 X 603 X 300	KV1	452045	⊗	KABELVERSCHRAUBUNG M32X1,5	AH1	438843	⊗	Clipfix 9,5mm	
	MECH1	504735	Montageplatte 550 x 550 x 3	KVM1	437227	⊗	MUTTER M32X1,5					
	MECH2	438813	Hutschiene TS 35x15/LL	TS 35x15/LL 540mm	KV2	438815	⊗	VERSCHRAUBUNG M25X1,5	A1	462661	⊗	Clipfix 5mm
	MECH3	438813	Hutschiene TS 35x15/LL	TS 35x15/LL 540mm	KVM2	441315	⊗	MUTTER M25X1,5				
B	AK1	430522	⊖	AUFKLEBER_FLIEGL_REFLEKTIERBAR_40X11	KV3	438815	⊗	VERSCHRAUBUNG M25X1,5	AH4	438843	⊗	Clipfix 9,5mm
	AK2	471921	⊖	AUFKLEBER_KABELVERLEGUNG_NICHT_PARALLEL	KVM3	441315	⊗	MUTTER M25X1,5	A2	462661	⊗	Clipfix 5mm
	AK3	468920	⊖	AUFKLEBER_ENDKONTROLLE_KLEIN	KV4	438815	⊗	VERSCHRAUBUNG M25X1,5	A3	462661	⊗	Clipfix 5mm
	AK4	431533	⊖	AUFKLEBER_WARNING_VOR_ELEKTRO_SPANNUNG	KVM4	441315	⊗	MUTTER M25X1,5	A4	462661	⊗	Clipfix 5mm
	AK5	463809	⊖	DREHRICHTUNGSPFEIL_FUER_MOTOREN	KV5	438815	⊗	VERSCHRAUBUNG M25X1,5	A5	462661	⊗	Clipfix 5mm
	KA1	457649	●	KONDENSATABLAUF	KVM5	441315	⊗	MUTTER M25X1,5	A6	462661	⊗	Clipfix 5mm
C				KV6	438815	⊗	VERSCHRAUBUNG M25X1,5	A7	462661	⊗	Clipfix 5mm	
				KVM6	441315	⊗	MUTTER M25X1,5	A8	462661	⊗	Clipfix 5mm	
				KV7	457260	⊗	VERSCHRAUBUNG M16X1,5	A9	462661	⊗	Clipfix 5mm	
				KVM7	457260	⊗	VERSCHRAUBUNG M16X1,5	A10	462661	⊗	Clipfix 5mm	
				KV8	457260	⊗	VERSCHRAUBUNG M16X1,5	A11	462661	⊗	Clipfix 5mm	
				KVM8	457260	⊗	VERSCHRAUBUNG M16X1,5	A12	462661	⊗	Clipfix 5mm	
				KV9	457260	⊗	VERSCHRAUBUNG M16X1,5	A13	462661	⊗	Clipfix 5mm	
				KVM9	457260	⊗	VERSCHRAUBUNG M16X1,5					
D	Litze	457842	—	H0_5V-K_DUNKELBLAU	KV10	457260	⊗	VERSCHRAUBUNG M16X1,5	DK1	441829	⊖	D-UT 2,5/4-TWIN
	Litze	458006	—	H0_5V-K_DUNKELBLAU/WEISS	KVM10	457260	⊗	VERSCHRAUBUNG M16X1,5	DK2	441829	⊖	D-UT 2,5/4-TWIN
	Litze	457845	—	H0_5V-K_GELB/GRUEN-1QMM					DK3	441829	⊖	D-UT 2,5/4-TWIN
	Litze	457841	—	H0_5V-K_HELLBLAU-1QMM	KV11	457260	⊗	VERSCHRAUBUNG M16X1,5	DK4	441829	⊖	D-UT 2,5/4-TWIN
	Litze	457843	—	H0_5V-K_ORANGE-1QMM	KVM11	457260	⊗	VERSCHRAUBUNG M16X1,5	DK5	441829	⊖	D-UT 2,5/4-TWIN
	Litze	457840	—	H0_5V-K_SCHWARZ-1QMM					DK6	442905	⊖	D-UT 2,5/10
	Litze	457189	—	H0_7V-K10_GELB/GRUEN-10QMM								
	Litze	439146	—	H0_7V-K_SCHWARZ-10QMM								
	Litze	439148	—	H0_7V-K_SCHWARZ-2,5QMM								
		AEH1	439719	⊖	1X0,5QMM_L=8MM_WEISS							
	AEH2	439713	⊖	1X1QMM_L=8MM_ROT								
	AEH3	439709	⊖	1X2,5QMM_L=8MM_BLAU								
	AEH4	439708	⊖	1X10QMM_L=12MM_ROT								
	AEH5	439712	⊖	2X1QMM_L=8MM_ROT								
	AEH6	439703	⊖	2X10QMM_L=14MM_ROT								
	FSH1	442141	⊖	FLACHSTECKHUELSEN_0,5-1QMM								
	KSH1	463192	⊖	PRESSKABELSCHUH_M8								
G	ROH1	440562	⊖	Rohrhalter 29mm								
	ROH2	440562	⊖	Rohrhalter 29mm								
	ISOL2	440561		KUNSTSTOFFISOLIERROHR_29MM								
	BR1	463304		ENDLOSSBRUECKE_BLAU								
H		SDI KARTE_1GB										
				Datum	18.03.2019							
			Bearb.	zaffral								
			Gepr.									
Änderung	Datum	Name	Norm									
1												
2												
3												
4												
5												
6												
7												

Katalog-Nr.:
Kunde: ---



mechanical parts

File name: Solo-Rondomat_600_2019-03-25
Job Number: AU-
Project Nb.: PR-
Article Nb.: 517063
Ser. Nb.:

Solo-Rondomat

Ass.Var:
PCB-Item Nb.: 000000

	1	2	3	4	5	6	7
A	ZB1 ZB2	453816 453816	PE PE	MECH6 439740	STOP-TASTE-RASTEND_SCHWAMM(ROT)		
	ZB4 ZB5 ZB6 ZB7 ZB8	453816 453816 453816 453816 453816	PE PE PE PE PE	MECH19 462554	STOP-TASTE-GELB_KREIS		
B	ZB9	438852	L1 L2 L3 N PE KKKKK	KSR1 456297	KUNSTSTOFFSCHILDER_RESET		
	ZB10	464174	N	SH20 455199	CARRIER-EMP_22		
C	ZB11	438852	L1	KSE1 455200	KUNSTSTOFFSCHILDER_AUS-EIN		
	ZB12	464176	-	SH19 455199	CARRIER-EMP_22		
	ZB13	464176	-	SH5 455199	CARRIER-EMP_22		
	ZB14 ZB15 ZB16	438856 438856 438856	1 2 3	KSB2 456296	KUNSTSTOFFSCHILDER_BETRIEB		
D	ZB17 ZB18 ZB19 ZB20	438856 438856 438856 438856	1 2 3 4	SH53 455199	CARRIER-EMP_22		
	ZB21 ZB22 ZB23 ZB24 ZB25	453815 453819 453820 453821 453822	d1 d2 d3 d4 d5	KSS2 456295	KUNSTSTOFFSCHILDER_STOERUNG		
E	ZB26 ZB27 ZB28 ZB29 ZB30	453824 453825 453826 453827 453828	i1 i2 i3 i4 i5				
F	ZB31 ZB32 ZB33 ZB34	438856 438856 438856 438856	1 2 1 2				
	KT1 KT2 KT3 KT4 KT5 KT6 KT7 KT8 KT9 KT10	462703 462703 462703 462703 462703 462703 462703 462703 462703 462703					
H			Datum 18.03.2019 Bearb. zaffral Gepr.	Katalog-Nr.:	mechanical parts		
				Kunde:	File name: Solo-Rondomat_600_2019-03-25		
				---	Job Number: AU- Project Nb.: PR- Article Nb.: 517063	Solo-Rondomat	
	Aenderung	Datum	Name	Norm	Ass.Var: PCB-Item Nb.: 000000	Blatt 18 von 21	
	1	2	3	4	5	6	7



Qty.	Article	Value	Part (s)
2	464695	1m grau	-W1, -W11
1	451896	3m grau	-W14
13	462661	Clipfix 5mm	A1, A2, A3, A4, A5, A6, A7, A8, A9, A10, A11, A12, A13
1	439719	1X0,5QMM L=8MM WEISS	AEH1
1	439713	1X1QMM L=8MM RÖT	AEH2
1	439709	1X2,5QMM L=8MM BLAU	AEH3
1	439708	1X10QMM L=12MM ROT	AEH4
1	439712	2X1QMM L=8MM RÖT	AEH5
1	439703	2X10QMM L=14MM ROT	AEH6
2	438843	Clipfix 9,5mm	AH1, AH4
1	430522	AUFKLEBER FLIEGL REFLEKTIERBAR 40X11	AK1
1	471921	AUFKLEBER KABELVERLEGUNG NICHT PARALLEL	AK2
1	468920	AUFKLEBER ENDKONTROLLE KLEIN	AK3
1	431533	AUFKLEBER WARNING VOR ELEKTRO SPANNUNG	AK4
1	463809	DREHRICHTUNGSPFEIL FUER MOTOREN	AK5
1	458193	1/4-433K2	ANT1
1	463304	ENDLOSSBRUECKE BLAU	BR1
1	488290	RJ45 F/F 8/8 CAT.5E	CX2
5	457622	PLC-RSC- 24DC/21AU	D1, D2, D3, D4, D5
5	441829	D-UT 2,5/4-TWIN	DK1, DK2, DK3, DK4, DK5
1	442905	D-UT 2,5/10	DK6
1	457842	H0 5V-K DUNKELBLAU	DRAHT1
1	458006	H0 5V-K DUNKELBLAU/WEISS	DRAHT2
1	457845	H0 5V-K GELB/GRUEN-1QMM	DRAHT3
1	457841	H0 5V-K HELLBLAU-1QMM	DRAHT4
1	457840	H0 5V-K SCHWARZ-1QMM	DRAHT5
1	457189	H0 7V-K10 GELB/GRUEN-10QMM	DRAHT6
1	439146	H0 7V-K SCHWARZ-10QMM	DRAHT7
1	439148	H0 7V-K SCHWARZ-2,5QMM	DRAHT8
1	457843	H0 5V-K ORANGE-1QMM	DRAHT9
1	452390	30W	E1
1	463705	ZEPHYR	EMPF1
1	439687	10A	F1
1	442141	FLACHSTECKHUELSEN 0,5-1QMM	FSH1
1	485678	24V 5A	G1
5	457621	PLC-VT/LA	I1, I2, I3, I4, I5
1	440561	KUNSTSTOFFISOLIERROHR 29MM	ISOL2
1	480470	XPS-AC5121	K1
1	457649	KONDENSATABLAUF	KA1

part list

Stückliste erzeugt : 25.03.2019 13:03:33			
	Datum	18.03.2019	
	Bearb.	zaffral	
	Gepr.		
Änderung	Datum	Name	Norm

Katalog-Nr.:	
Kunde:	---



File name:	Solo-Rondomat_600_2019-03-25
Job Number:	AU-
Project Nb.:	PR-
Article Nb.:	517063
Ser. Nb.:	

Solo-Rondomat	
Ass.Var:	
PCB-Item Nb.:	000000
Blatt 19 von 21	

Qty.	Article	Value	Part (s)
1	456296	KUNSTSTOFFSCHILDER_BETRIEB	KSB2
1	455200	KUNSTSTOFFSCHILDER_AUS-EIN	KSE1
1	463192	PRESSKABELSCHUH_M8	KSH1
1	456297	KUNSTSTOFFSCHILDER_RESET	KSR1
1	456295	KUNSTSTOFFSCHILDER_STOERUNG	KSS2
10	462703	KLM_3-L	KT1,KT2,KT3,KT4,KT5,KT6,KT7,KT8,KT9,KT10
1	452045	KABELVERSCHRAUBUNG_M32X1,5	KV1
5	438815	VERSCHRAUBUNG_M25X1,5	KV2,KV3,KV4,KV5,KV6
10	457260	VERSCHRAUBUNG_M16X1,5	KV7,KV8,KV9,KV10,KV11,KVM7,KVM8,KVM9,KVM10,KVM11
1	437227	MUTTER_M32X1,5	KVM1
5	441315	MUTTER_M25X1,5	KVM2,KVM3,KVM4,KVM5,KVM6
3	442886	UT_10	L1,L2,L3
12	441825	UT_2,5-TWIN	L4,X3_1,X3_2,X3_3,X3_4,X4_1,X4_2,X4_3,X5-1,X5-2,X6-1,X6-2
1	504735	MONTAGEPLATTE_550X550X3MM	MECH1
1	462554	STOP-TASTE-GELB_KREIS	MECH19
2	438813	TS_35x15/LL_540mm	MECH2,MECH3
1	439740	STOP-TASTE-RASTEND_SCHWAMM(ROT)	MECH6
1	442885	UT_10_BU	N-1
1	441826	UT_2,5-TWIN_BU	N1
1	440289	LED_green	P1
1	440290	LED_red	P2
1	497013	G07T-TOUCH-PANEL	P4
1	442884	UT_10-PE	PE-1
7	441827	UT_2,5-TWIN-PE	PE1-8,PE5,PE_M1,PE_M2,PE_M3,PE_M5,X1
1	438630	VCF3//63A	Q1
5	441043	LUCA32	Q2,Q3,Q4,Q5,Q6
5	441044	LUCA32	Q2.1,Q3.1,Q4.1,Q5.1,Q6.1
5	441040	LUCA32	Q2.2,Q3.2,Q4.2,Q5.2,Q6.2
2	440562	Rohrhalter_29mm	ROH1,ROH2
1	440288	XB5AP61 / BLAU	S2
1	??????	XB5AP61 / BLAU	S2.1
1	439768	NOTHALT_2X_OEFFNER_MIT_AUFKLEBER	S3
1	452522	NOTHALT_2X_OEFFNER_MIT_AUFKLEBER	S3.1
1	439740	NOTHALT_2X_OEFFNER_MIT_AUFKLEBER	S3.2
1	469741	NOTHALT_2X_OEFFNER_MIT_AUFKLEBER	S3.3
1	459125	TEMP_REG_HEIZEN	S4
4	441835	FBS_2-5	SB1,SB2,SB3,SB4
1	464736	SD_KARTE_1GB	SD1
1	480724	SCHALTSCHRANK_606X606X300_FLG-004	SH1

H Stückliste erzeugt : 25.03.2019 13:03:33

Datum	18.03.2019
Bearb.	zaffral
Gepr.	
Norm	
Änderung	Datum
	Name

Katalog-Nr.:
Kunde: ---



part list

File name: Solo-Rondomat_600_2019-03-25

Job Number: AU-
Project Nb.: PR-
Article Nb.: 517063
Ser. Nb.:

Solo-Rondomat

Ass.Var:
PCB-Item Nb.: 000000

Blatt 20 von 21

Qty.	Article	Value	Part (s)
4	455199	CARRIER-EMP_22	SH5, SH19, SH20, SH53
1	502928	EC-COM_02	SPS1
1	502927	EC_1000_SPS	SPS2
1	502930	EC_1000_XR01-E	SPS3
1	502929	EC_1000_XR02_E	SPS4
1	489058	EB-PSE-24V-1	T2
2	458836	UT_2,5-MT	X.1, X3
1	458210	24V-A-XX-	X11-1
1	458210	GND-A-XX-	X11-2
1	455001	RS485M12F	XC1
1	455052	M12F/5WANDDURCHFUEHRUNG	XC2
7	453816	PE	ZB1, ZB2, ZB4, ZB5, ZB6, ZB7, ZB8
1	464174	N	ZB10
1	438852	L1	ZB11
2	464176	-	ZB12, ZB13
4	438856	1	ZB14, ZB17, ZB31, ZB33
4	438856	2	ZB15, ZB18, ZB32, ZB34
2	438856	3	ZB16, ZB19
1	438856	4	ZB20
1	453815	d1	ZB21
1	453819	d2	ZB22
1	453820	d3	ZB23
1	453821	d4	ZB24
1	453822	d5	ZB25
1	453824	i1	ZB26
1	453825	i2	ZB27
1	453826	i3	ZB28
1	453827	i4	ZB29
1	453828	i5	ZB30
1	438852	ZACKBAND-5_10MM	ZB9

H Stückliste erzeugt : 25.03.2019 13:03:33

Katalog-Nr.:



part list

File name: Solo-Rondomat_600_2019-03-25

Job Number: AU-
 Project Nb.: PR-
 Article Nb.: 517063
 Ser. Nb.:

Solo-Rondomat

Ass.Var:
 PCB-Item Nb.: 000000

Blatt 21 von 21

1	2	3	4	5	6	7
Änderung	Datum	Name	Norm	Kunde:	---	