

DC1000 Dialog-Controller Basic, Prime, Compact, Clean

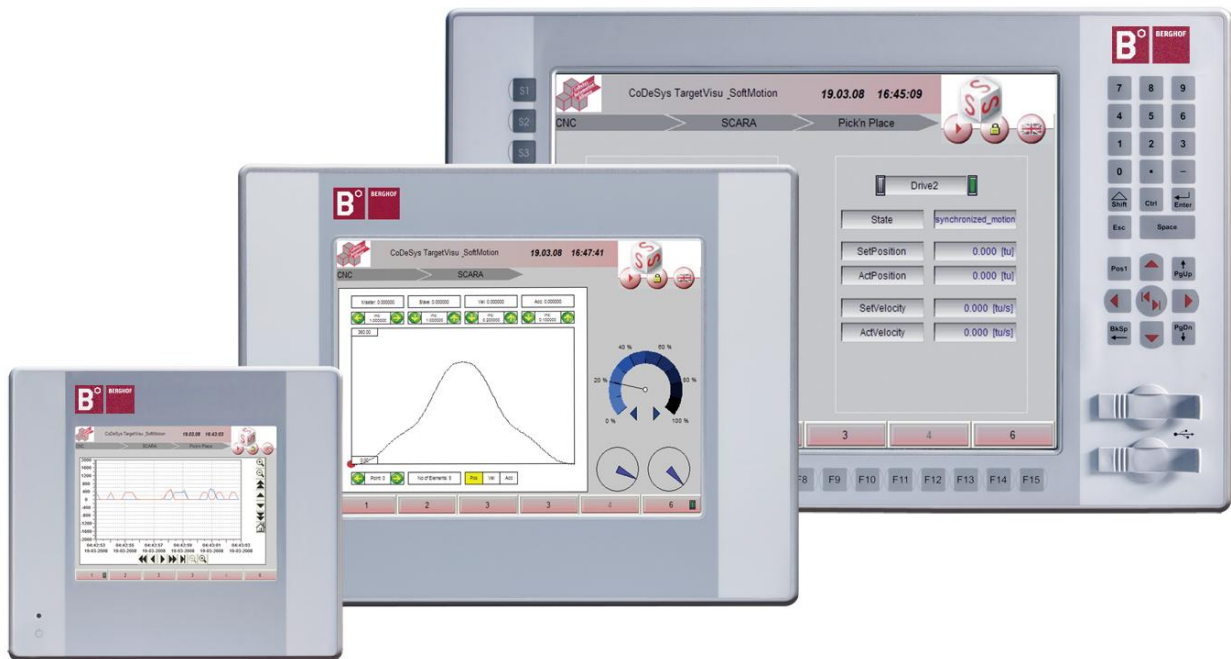

Copyright © Berghof Automation GmbH

Reproduction and duplication of this document and utilisation and communication of its content is prohibited, unless with our express permission. All rights reserved. Damages will be payable in case of infringement.

Disclaimer

The content of this publication was checked for compliance with the hardware and software described. However, discrepancies may arise, therefore no liability is assumed regarding complete compliance. The information in this document will be checked regularly and all necessary corrections will be included in subsequent editions. Suggestions for improvements are always welcome.

Subject to technical changes.

Trademarks

- CANtrol® and CANtrol®- dialog are registered trademarks of Berghof Automation GmbH
- Microsoft®, Windows® and the Windows® Logo are registered trademarks of Microsoft Corporation in the USA and other countries.
- EtherCAT® is a registered trademark and patented technology, licensed from Beckhoff Automation GmbH, Germany.
- CiA® and CANopen® are registered community trademarks of CAN in Automation e.V.

All rights reserved by the individual copyright holders.

General Information on this Manual

This equipment manual contains product-specific information valid at the time of publication.

This equipment manual is only complete in conjunction with the product-related hardware and software user manuals required for the individual application.

→ [Content](#)

→ [Completeness](#)

You can reach us at:

Berghof Automation GmbH

Harretstr. 1

72800 Eningen

Germany

T +49.7121.894-0

F +49.7121.894-100

e-mail: controls@berghof.com

www.berghof.com

Berghof Automation GmbH works in accordance with DIN EN ISO 9001:2000.

Update

Version	Date	Subject
1.1	22.09.2006	First version
1.2		Inexistent
1.3	31.05.2007	Dimensions updated under "Technical specifications" and in the graphs. Plug/unplug cycles added to the "USB pin assignment" section of the "Technical specifications". Description, "Chemical resistance for touch screens and I/O-Modules" included. Notice to "SD-card reader" included. Update under "Power supply - internal power pack", "Profibus master card" and "Profibus slave card".
1.4	23.09.2009	General revision. New chapter: "Copyright and software licenses".
1.5	28.10.2009	Supplement of technical data for DC 1005, 1010 and 1012. Update of "Service Menu" chapter.
1.6		Inexistent
1.7	07.04.2011	Updates of "Declaration of conformity", "Chemical resistance" and "Notes on the copyright and software license". Description of DC1010 Compact (CP) and DC1012 Compact (CP) incorporated, XR01 and XR02 extension modules inserted. "Battery change" diagram corrected. Corrections of the DC1010 (CP) "Panel cut-out", DC1012 "Technical data" (dimensions), new warning for XR01 and XR02 I/O cards (power supply) integrated.
1.8	08.11.2012	Update in the "Declaration of conformity" section. Note on terminating resistors, switches S2+S3 with Profibus Master/Slave card inserted. Update of chapter "Annex, Standards / Bibliography". Update of the trademarks. Update in the "DC1010 Compact (CP) panel cutout" section.
1.9	04.09.2013	Transition into new CD. New corporate name "Berghof Automation GmbH". Update of chapter "Extension modules".
1.10	03.05.2016	New EMC directive. Correction standards. Update of chapter "Chemical resistance". Update of section "Nameplate".

Blank page

Contents

- 1. GENERAL.....9**
- 1.1. About this manual.....9
- 1.2. Hazard categories and terminology.....10
- 1.3. Qualified personnel.....11
- 1.4. Due diligence.....11
- 1.5. Basic safety measures.....12
- 1.6. Use as prescribed13
- 1.7. Conformity declaration14
- 1.7.1. Extension modules.....14
- 1.8. Transport and setup.....15
- 2. PRODUCT DESCRIPTION17**
- 2.1. Identification.....19
- 2.2. The different versions of the Dialog-Controller.....20
- 2.2.1. Interfaces.....20
- 2.2.2. Front foil sheeting.....20
- 2.2.3. Overview of types.....21
- 2.2.4. Variable thanks to extension cards.....21
- 2.3. Dialog-Controller DC1005 / DC1010 / DC1012 construction.....22
- 2.3.1. Block circuit diagram.....22
- 2.4. Technical data DC100523
- 2.4.1. DC1005 Front view.....25
- 2.4.2. DC1005 Rear view.....25
- 2.4.3. DC1005 Dimensions.....26
- 2.4.4. DC1005 Panel cutout.....27
- 2.4.5. Mounting regulation DC1005.....27
- 2.5. Technical data DC101028
- 2.5.1. DC1010 Front view.....30
- 2.5.2. DC1010 Rear view.....30
- 2.5.3. DC1010 Dimensions.....31
- 2.5.4. DC1010 Panel cutout.....32
- 2.5.5. Mounting regulation DC1010.....32
- 2.6. Technical data DC1010 Compact (CP).....33
- 2.6.1. DC1010 Compact (CP) front view.....35
- 2.6.2. DC1010 Compact (CP) rear view.....35
- 2.6.3. DC1010 Compact (CP) dimensions.....36
- 2.6.4. DC1010 Compact (CP) panel cutout.....37
- 2.6.5. Mounting regulation DC1010 Compact (CP).....37
- 2.7. Technical data DC101238
- 2.7.1. DC1012 Front view.....40
- 2.7.2. DC1012 Rear view.....40
- 2.7.3. DC1012 Dimensions.....41
- 2.7.4. DC1012 Panel cutout.....42

2.7.5. Mounting regulation DC1012.....	42
2.8. Technical data DC1012 Compact (CP).....	43
2.8.1. DC1012 Compact (CP) front view	45
2.8.2. DC1012 Compact (CP) rear view	45
2.8.3. DC1012 Compact (CP) dimensions	46
2.8.4. DC1012 Compact (CP) panel cutout.....	47
2.8.5. Mounting regulation DC1012 Compact (CP).....	47
2.9. Mounting and connection.....	48
2.9.1. Mounting	48
2.9.2. Connections	48
2.10. Pin assignment.....	49
2.10.1. Pin overview	49
2.10.2. Power supply.....	49
2.10.3. 10/100 Base-T Network Connection (Ethernet).....	49
2.10.4. USB.....	50
2.10.5. CAN bus.....	51
2.10.6. Serial ports	52
2.10.7. E-bus.....	55
2.10.8. Connections for expansion ports.....	55
2.11. SD card.....	56
3. DIALOG-CONTROLLER OPERATION	57
3.1. Commissioning	57
3.2. Function selection, indicators, diagnostics.....	57
3.2.1. Status indicators.....	57
3.3. Service menu	59
3.3.1. Using the service menu.....	60
3.3.2. Parameter window.....	60
“Config” service menu	61
“PLC” service menu.....	64
“INFO” service menu	65
“Display” service menu.....	66
3.3.3. PLC window	67
3.4. Decommissioning	70
3.4.1. Disposal	70
3.5. Maintenance.....	71
3.6. Help in case of problems.....	71
4. EXTENSION MODULES.....	73
4.1. I/O card with SC-CAN interface.....	74
4.1.1. Technical data	75
4.1.2. Pin assignment.....	77
4.1.3. Analog inputs	81
4.1.4. Digital inputs/outputs 12/4/8-0.5.....	82
4.1.5. Digital inputs, positive switched.....	83
4.1.6. Digital outputs, positive switched.....	86
4.1.7. Digital input/output pin assignments.....	89

4.2. PROFIBUS-MASTER card	91
4.2.1. Technical data	92
4.2.2. Front view and pin assignment	93
4.3. PROFIBUS-SLAVE card	96
4.3.1. Technical data	97
4.3.2. Front view and pin assignment	98
4.4. PROFIBUS card (Master/Slave functionality)	101
4.4.1. Technical data	102
4.4.2. Front view and pin assignment	103
4.5. I/O XR01 and XR02 cards with analog and digital I/O	106
4.5.1. Technical data	107
4.5.2. Pin assignment	108
4.5.3. Power supply	108
4.5.4. Plug-in connectors	109
4.5.5. Installation	110
4.5.6. 8/8-0.5 digital inputs/outputs	110
4.5.7. Terminal assignment of digital inputs/outputs	116
4.5.8. Analog inputs/outputs	117
5. MAINTENANCE	127
5.1. Real-time clock with backup battery	128
5.1.1. Battery replacement	129
6. CHEMICAL RESISTANCE	131
6.1. Resistance of the touch screen	131
6.2. Resistance of the AUTOTEX front foil sheeting to chemicals	132
6.2.1. General resistance of the foil sheeting material	132
6.2.2. Resistance to household chemicals	133
6.2.3. Environmental values	133
6.3. Resistance of the AUTOFLEX- front foil sheeting to chemicals	134
6.3.1. General resistance of the foil sheeting material	134
6.3.2. Resistance to household chemicals	135
6.3.3. Outdoor use	135
7. COPYRIGHT AND SOFTWARE LICENSES	137
8. ANNEX	139
8.1. Environmental Protection	139
8.1.1. Emission	139
8.1.2. Disposal	139
8.2. Maintenance/Upkeep	139
8.3. Repairs/Service	139
8.3.1. Warranty	139
8.4. Nameplate	140
Nameplate descriptions (example)	140
8.5. Addresses and Bibliography	141
8.5.1. Addresses	141

8.5.2. Standards/Bibliography 142

1. General

Documentation





This equipment manual is intended for qualified personnel and contains information regarding the mounting, installation, commissioning and maintenance of the Dialog Controller. The information contained in this manual is subject to change without prior notice.

1.1. About this manual

This equipment manual is an integral part of the product. Make sure the equipment manual is always available near the product's point-of-employment. The manual contains information about the following topics

- Areas of application
- Safety
- Mechanical construction
- Electrical construction
- Connections
- Commissioning
- Care and maintenance
- Decommissioning
- Disposal

1.2. Hazard categories and terminology

 <p>DANGER</p>	<p>Immediate danger</p> <p>Failure to observe the information indicated by this warning will result in death, serious injury or extensive property damage.</p>
 <p>WARNING</p>	<p>Potential danger</p> <p>Failure to observe the information indicated by this warning may result in death, serious injury or extensive property damage.</p>
 <p>CAUTION</p>	<p>Danger</p> <p>Failure to observe the information indicated by this warning may result in injury or property damage.</p>
 <p>NOTICE</p>	<p>No hazard</p> <p>Information indicated in this manner provides additional notes concerning the product.</p>

1.3. Qualified personnel

Only qualified personnel may install, operate and maintain the Dialog Controller.

Within the context of this documentation and the safety information it contains, qualified personnel constitutes trained specialists who have the authority to mount, install, commission, ground and identify equipment, systems and power circuits in accordance with the standards of safety technology, and who are familiar with the safety concepts of automation technology.

1.4. Due diligence

The operator or original equipment manufacturer (OEM) must ensure ...

- that the Dialog Controller is only employed for its intended use.
- that the Dialog Controller is only employed in a fault-free, operational state.
- that the equipment manual is always maintained in a complete and legible condition and is available at the point-of-employment of the Dialog Controller.
- that only properly qualified and authorized personnel mount, install, commission and maintain the Dialog Controller.
- that these specialists receive regular and ongoing instruction in all pertinent questions related to work safety and environmental protection and that they are familiar with the contents of the equipment manual, in particular, with the safety information it contains.
- that the equipment identifiers as well as safety and warning information applied to the Dialog Controller are not removed and that they are maintained in a legible condition.
- that all international, federal, state and local ordinances governing the control of machinery and equipment applicable at the location at which the Dialog Controller is employed are complied with.
- that the users always have available all relevant information they require with regard to the Dialog Controller and its employment.

1.5. Basic safety measures

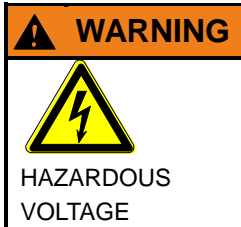

If damage can be seen on the faceplate of the dialog controller, the device must not be operated any more! It must be disconnected from the supply voltage immediately!

Besides the danger of injury owing to the visibly sharp edges, there is also the risk of touching parts under high voltage. Contact with high voltage can still occur even some time after the supply voltage has been shut off.

Working on the DC

Before beginning work on the Dialog Controller you must always

- first ensure that the equipment is in a safe state,
- then first switch the DC off, followed by the equipment, and
- only then disconnect the DC from the equipment.



Hazards due to unforeseeable functional and processing movements when the Industrial PC is disconnected.

These can result in death, serious injury or extensive property damage.

All equipment components must be disconnected from the Dialog Controller whenever the Dialog Controller is not being used for operational or control purposes, e.g., during maintenance or during functional checks after repairs.

Lock out and tag out all equipment components after they have been switched off!

Opening the DC

First, please note all the tasks steps outlined in the above section “Working on the DC”. The supply voltage must be switched off before opening the housing or when components are being installed or removed.

To do this, switch the power supply to the Dialog Controller off. Then remove the plug from the power supply socket on the Dialog Controller.

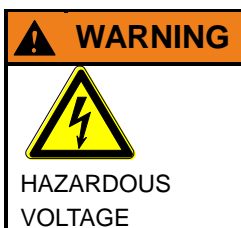

Do not open the housing cover with the power switched on!

Hazard due to contact with live components.

This can result in death, serious injury or extensive property damage.

Only open the housing cover once the Dialog Controller has been safely disconnected from the power supply.

1.6. Use as prescribed

This is a modular automation system based on the CANbus, intended for industrial control applications within the medium to high performance range.

The automation system is designed for use within Overvoltage Category I (IEC 364-4-443) for the controlling and regulating of machinery and industrial processes in low-voltage installations in accordance with the following general parameters:

- maximum rated supply voltage of 1,000 VAC (50/60 Hz) or 1,500 VDC;
- for use in maximum category 2 pollution environment (EN 60950);
- for use up to a maximum altitude of 2,000 m above msn;
- for indoor use only in areas not exposed to direct UV radiation;
- max. ambient temperature inside and outside the control cabinet is within the technical specifications (see section “Technical data”)

Qualified project planning and design, proper transport, storage, installation, use and careful maintenance are essential to the flawless and safe operation of the automation system.

The automation system may only be used within the scope of the data and applications specified in the present documentation and associated user manuals.

The automation system is to be used only as follows:

- as prescribed
- in technically flawless condition
- without arbitrary or unauthorized changes
- exclusively by qualified users

The regulations of the German professional and trade associations, the German technical supervisory board (TÜV), the VDE (Association of German electricians) or other corresponding national bodies are to be observed.

Safety-oriented (fail-safe) systems

Particular measures are required in connection with the use of SPC in safety-oriented systems. If an SPC is to be used in a safety-oriented system, the user ought to seek the full advice of the SPC manufacturer in addition to observing any standards or guidelines on safety installations which may be available.



As with any electronic control system, the failure of particular components may result in uncontrolled and/or unpredictable operation.

All types of failure and the associated fuse systems are to be taken into account at system level. The advice of the SPC manufacturer should be sought if necessary.

1.7. Conformity declaration

Both the standard version of the Dialog Controller and with the extension modules mentioned below comply with and make allowance for the following directives and standards:

- **EMC Directive 2014/30/EU**
- **EN 61131-2:2007** Programmable logic controllers
Part 2: Equipment requirements and tests
Class B, connector cable of the I/O, max 30 m
- **EN 61000-6-2:2005/AC:2005** Electromagnetic compatibility (EMC)
Part 6-2: Generic standard – immunity for industrial environments
- **EN 61000-6-4:2007/A1:2011** Electromagnetic compatibility (EMC)
Part 6-4: Generic standard – electrostatic discharge for industrial environments

1.7.1. Extension modules

Conformity is declared to the above-stated directives for the extension modules given below, built into the Dialog-Controller:

- PROFIBUS-MASTER card
- PROFIBUS-SLAVE card
- PROFIBUS card (Master/Slave functionality)
- I/O cards XR01 and XR02 with analog and digital I/O

No general conformity can be declared for extensions with contact line system, built into the Dialog-Controller:

- I/O card with SC-CAN interface

With connected contact line system the compliance of the EMC requirements on the complete system must be checked and ensured („fixed installation“ for the purpose of the EMC directive).

1.8. Transport and setup



Please note the specified storage conditions in the section “Technical specifications”.

Transport

Protect the Dialog Controller against extreme mechanical stress during transport. Always transport the Dialog Controller in its original packaging. The built-in components are extremely sensitive to jarring and strong vibrations.

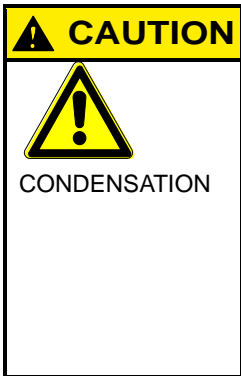

Condensation hazard resulting from climatic fluctuations

Risk of damage as a result of moisture forming on or in the Dialog Controller (condensation). This can result in destruction of the device or consequential damages.

After storage or transport in cold weather or under conditions of strongly fluctuating temperatures, the Dialog Controller must be allowed to slowly adjust to the ambient temperature at its point of use before it can be taken into service.

In case of condensation, the unit may not be taken into service for at least 12 hours (temperature compensation).

Unpacking

Proceed as follows:

- Inspect the packaging for any external damage. If the packaging is severely damaged or if damage to the contents can be detected, do not open the packaging any further. Immediately contact your shipper and your supplier.
- Remove the packaging. Do not discard the original packaging! The packaging can be used for subsequent transport.
- Inspect the contents for visible shipping damage.
- Check the contents against the order for completeness. Save all included documentation. This documentation contains important information concerning the Dialog Controller and is an integral part of the product.
- If shipping damage is detected or if the received contents do not agree with the order, please contact your supplier immediately.

Setup

This Dialog Controller is designed for installation in fully enclosed circuit cabinets of industrial machinery and equipment. When installing the Dialog Controller, take particular care to ensure that the included seal profiles are not damaged. Also ensure compliance with the ambient conditions specified under “Technical specifications”.

Blank page

2. Product description

The Dialog-Controller is a real-time control module with a display and a broad spectrum of data interfaces. [→ Short description](#)
The module can be programmed in 'C' or in accordance with IEC 61131-3 (CODESYS 2.3).

Installation

The Dialog-Controllers are intended for front panel or switch cabinet installation in harsh industrial environments. Maintenance is minimal, thanks to their fan-free design and flash memory.

Processors

The Dialog-Controller is equipped with either a 266 MHz or 400 MHz POWERPC™ processor from Freescale.

Display

The great differences in the appearance of the Dialog-Controller are based on the selection of the employed display technology and a common display diagonal size. 5.7" units with a monochrome (STN), color (CSTN) or TFT display are available. Above a diagonal screen size of 10.4" only TFT displays are employed. Unit housing dimensions and protective method (IP65 on the front) do not depend on whether the version in question has a touch screen or matrix keypad.

Ethernet

A 10/100 MBit/s Ethernet interface is included. TCP/IP and UDP/IP protocols offer highly flexible connections to visualization software, higher order control units or an IT infrastructure.

USB ports

The two USB host ports provide interfaces for widely dispersed peripheral devices. For example, one USB stick can be used to quickly and easily perform application updates or data extraction. Please contact our Technical Support if no driver support is available for a specific USB device.

CAN ports

The Dialog-Controller is equipped with two standard CAN interfaces, both of which can be operated at 1 MBit/s.

Serial ports

A total of three serial ports can be used on the Dialog-Controller. The RS232 programming interface is supplemented by an additional RS232 and an RS485 port.

E-bus extension

The Dialog-Controller's I/O level can be expanded via the E-bus socket to include up to seven E-bus subscribers.

Expansion slots

The device is equipped with three expansion slots for expansion cards (e.g., I/O cards) with the associated SPI interface. Alternately, one of the slots can be used for an “Anybus[®]” embedded bus module (e.g., Profibus DP) manufactured by HMS.

Real-time clock

A software interface can be used to set or reset a real-time clock equipped with a backup battery.

SD card reader

Data can be written to or read from memory cards using the conventional MMC/SD card interfaces.



If the SD card reader is activated, then the second RS232 interface (X5) is not longer available.

Performance feature overview

- Freescale POWERPC™ CPU 266 (400) MHz
- Application program and data memory (RAM): 64 (128) MB onboard / 32 (96) MB for the application
- Application program memory (Flash): 16 (32) MB onboard / 8 (24) MB for the application
- Retain memory 16 KB
- 1 Ethernet 10/100 port
- 1 (3) USB host ports
- 1 (2) CAN ports
- 1 RS232 serial port for programming tools and applications
- 1 (2) serial data ports RS232 / RS485
- I/O level locally expandable via an internal E-bus for up to seven subscribers (digital / analog)
- Up to 3 onboard expansion slots for I/Os and a bus module
- Real-time clock
- MMC/SD card slot

→ [Scope of supply](#)

The scope of supply of the controller module consists of:

- Dialog-Controller DC10xx
incl. 2-pin plug-in connector for power supply

2.1. Identification

Product: Dialog-Controller, Type DC10xx

Identification code

The features of the Dialog-Controller (see nameplate) can be itemised according to the identification code.

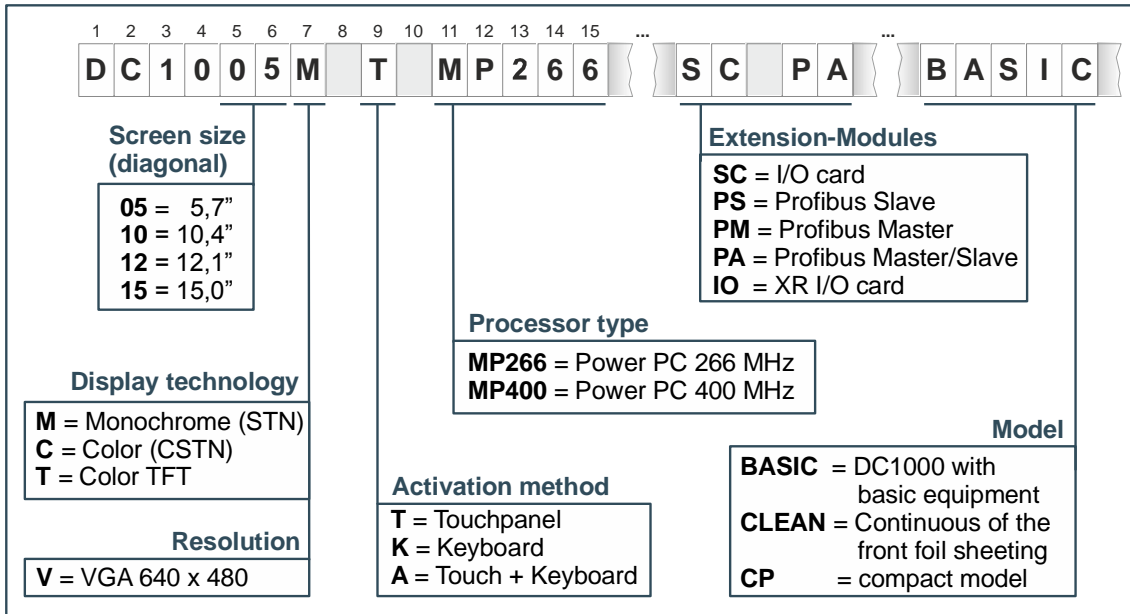

2VF100227DG04.cdr

2.2. The different versions of the Dialog-Controller

2.2.1. Interfaces

→ Prime Interface

Communication is the forte of the DC1000. Its spectrum of interfaces and extension options makes it the reason for this. The DC1000 with a Prime interface is extremely adaptable.

The maximum scope of the interfaces can be supplemented with further communication and I/O extension cards. So it is easy to always find the right automation solution.



2VF100397DG00.cdr

→ Basic Interface

The DC1000 with the Basic Interface is optimal for standard applications. With high processor power and equipped minimally with interfaces, it is the right solution for a price sensitive market.



2VF100398DG00.cdr

2.2.2. Front foil sheeting

→ Clean Touch

If cleanliness is a priority, the Clean Front is the right choice. Dust and dirt do not stand a chance here; and what's more, it is easy to clean.



2VF100399DG01.cdr

→ Connect Touch

Machine parameters or data records can be exchanged simply and fast by means of a USB stick. It is very convenient to have a USB port available at the front. The Connect front is distinguished by the USB port at the front with IP65 cover.



2VF100400DG01.cdr













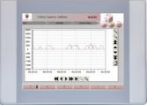
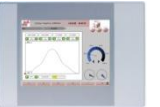
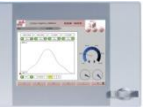

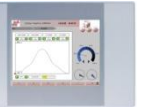

→ Connect Key

Touch screen or membrane key pad: this is not merely a philosophical operational issue. Gloves are often needed on site. If this is the case, keys are simple and safe to use.



2VF100401DG01.cdr

2.2.3. Overview of types

		Prime Interface				Basic Interface
		Clean Touch	Connect Touch	Connect Key	Compact Touch	Clean Touch
12,1"	SVGA 800 x 600 65536 colours (16 bit p. P.)					
			DC1012T T	DC1012T K	DC1012T T Clean	
10,4"	VGA 640 x 480 65536 colours (16 bit p. P.)					
		DC1010T T Clean	DC1010T T	DC1010T K	DC1010T T Clean	DC1010T T Basic
5,7"	VGA 640 x 480 65536 colours (16 bit p. P.)					
		DC1005V T Clean	DC 1005V T	DC1005V K		DC1005V T Basic
	QVGA 320 x 240 256 colours (8 bit p. P.)					
		DC1005T T Clean	DC1005T T	DC1005T K		DC1005T T Basic
	QVGA 320 x 240 monochrome 4 shades of grey					
		DC1005M T Clean	DC1005M T	DC1005M K		DC1005M T Basic

2.2.4. Variable thanks to extension cards

The DC1000 can be fitted with a maximum of three extension cards. The spectrum encompasses pure I/O cards as well as communication cards, which are already installed by Berghof. The range is constantly being extended conforming to the market requirements. Extension cards can only be fitted in Dialog-Controllers with Prime Interface.

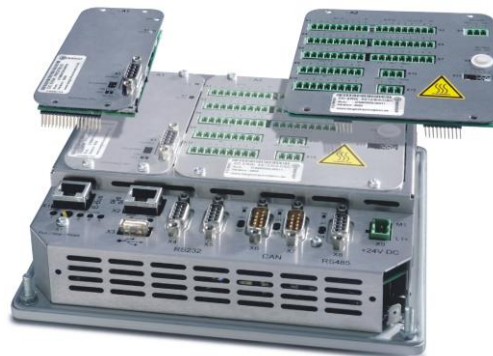

2VF100403DG00.cdr

2.3. Dialog-Controller DC1005 / DC1010 / DC1012 construction

2.3.1. Block circuit diagram

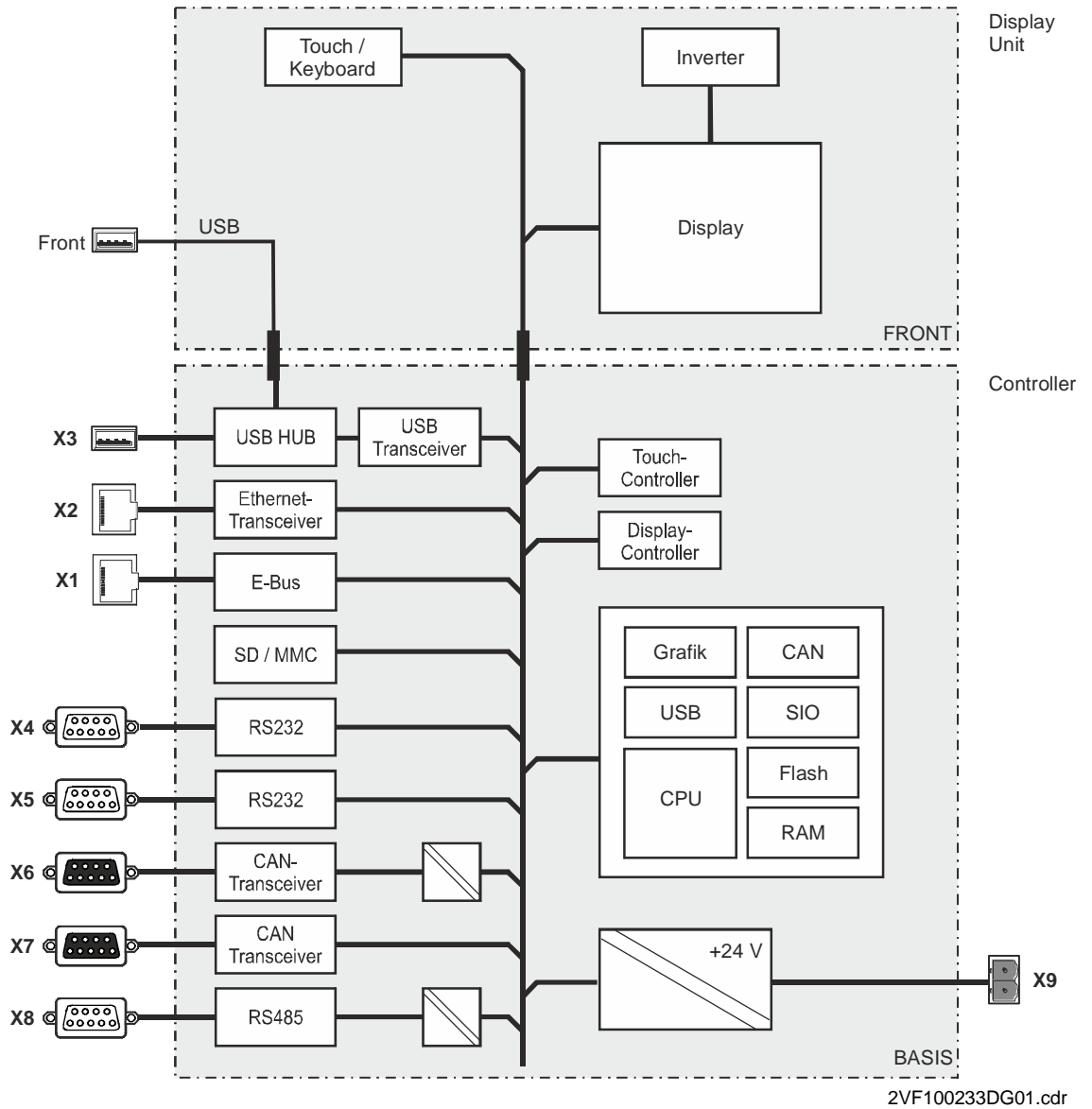

No potential isolation of the CAN and RS485 interface on the Basic Interface version.

2.4. Technical data DC1005

Module data		
Display	1/4 VGA	VGA
Diagonal measurement	5.7"	
Resolution	320 x 240 pixels	640 x 480 pixels
Colors	Monochrome (STN): 4 Color (CSTN): 256 (8 bits / pixel) Color TFT: 256 (8 bits / pixel)	Color TFT: 65536 (16 bits / pixel)
CPU, application memory		
CPU	Freescall PowerPC 266 MHz	400 MHz
Program memory (Flash)	16 MB onboard / 8 MB for application	32 MB onboard / 24 MB for application
Program memory and data memory (RAM)	64 MB onboard / 32 MB for application	128 MB onboard / 96 MB for application
Retain memory	16 kB	
Development environment	CP1131 (CODESYS 2.3)	
Dimensions and weights		
Dimensions (WxHxD [mm])	194x172x52 (+6 mm front panel)	
Weight	Approx. 1.5 kg	
Operating conditions		
Ambient temperature range	0 °C to +55 °C (if installation rule is adhered to)	
Relative humidity	Max. 85 %, non-condensing (monochrome: max. 75 %)	
Transport, storage		
Ambient temperature range	-20 °C to +70 °C	
Relative humidity	Max. 85 %, non-condensing (monochrome: max. 75 %)	
Shock resistance		
Vibration	Sinusoidal (EN 60068-2-6) test: Fc 10 ... 150 Hz, 1 G (operation mode)	
Shock resistance	15 G (approx. 150 m/s ²); duration:10 ms; semi-sinusoidal (EN 60068-2-27) test: Ea	
EMC, protection type		
Interference emission	EN 61000-6-4, industrial environments	
Interference resistance	EN 61000-6-2, industrial environments	
Protection class	III	
Insulating resistance	EN 61131-2; DC 500 V test voltage	
Protection type	IP20 (front: IP65)	

Module data	
Power supply (24 V power pack)	
Supply voltage	+24 VDC (-15 % / +20 %) SELV, max. alternating component: 5 %, max. voltage interruption 1 ms (10 ms only with power supply after 61131-2)
Current consumption	Typically 1.0 A; max. 2.0 A at +24 VDC; Fusing depending on the I/O load, max. 12 A
Polarity reversal protection	Yes
Potential isolation	Yes, between CAN bus and I/Os.
Ethernet port	
Number / interface type	1 x 10/100 Base-T
Connection method	RJ45
USB ports	
Number / interface types	1 x host USB, Rev. 1.1 (on rear) 1 x host USB, Rev. 1.1 (on front, on Prime Interface version)
Plug/unplug cycles	Max. 1,000
CAN bus ports	
Number / interface types	2 x Standard CAN ISO 11898 1 x Standard CAN ISO 11898 on Basic Interface
Potential isolation	CAN0 (X6) potential isolated (Prime Interface only)
Transmission rate	Max. 1 Mbit/s
Terminating resistor	Switchable
Serial ports	
Number / interface types	2 x RS232 (1x RS232 on Basic Interface) 1 x RS485
Potential isolation	RS485 (X8) potential isolated (Prime Interface only)
Terminating resistor	Switchable with the RS485
E-bus port	
Interface type	I/O expansion bus for up to 7 E-bus subscribers
Expansion slots	
Number / interface types	3 slots for 3 I/O modules or 2 I/O modules and one AnyBus [®] module (Prime Interface only)
Further features	
Real-time clock	Yes, battery backed.
SD card	1 SD card slot or RS232 (X5) (Prime Interface only)

2.4.1. DC1005 Front view

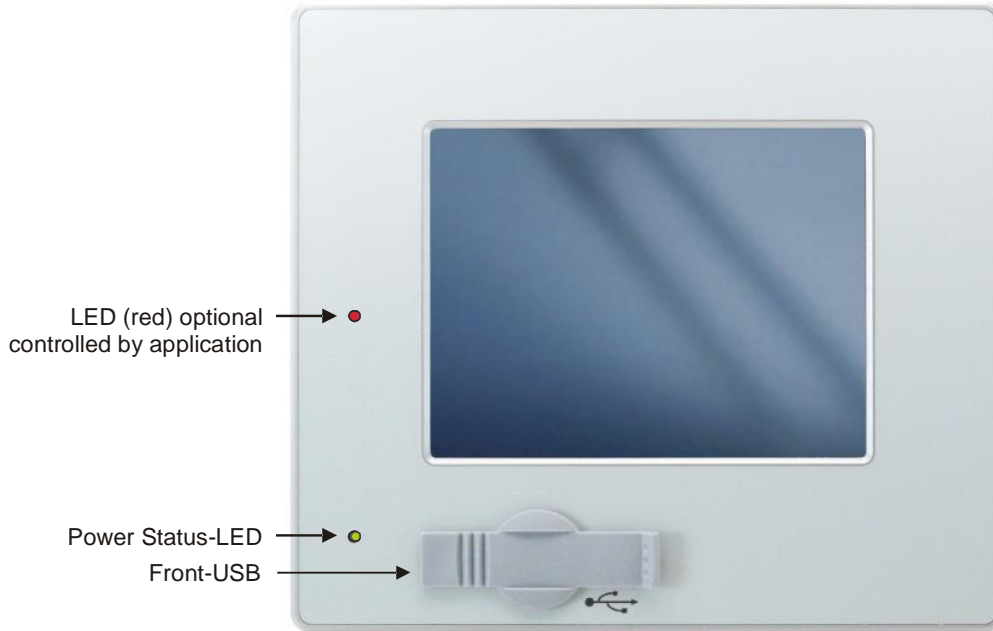

2VF100229DG01.cdr

2.4.2. DC1005 Rear view



2VF100230DG01.cdr

2.4.3. DC1005 Dimensions

Dimensions are identical for units equipped with either a keyboard or a touchpad.

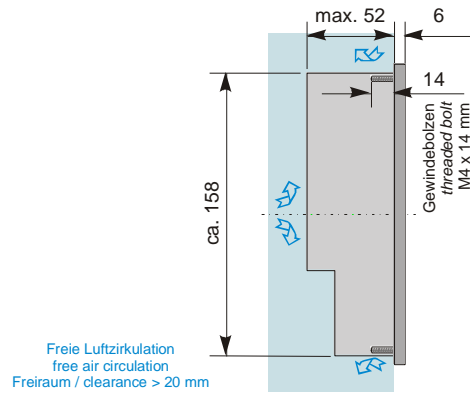
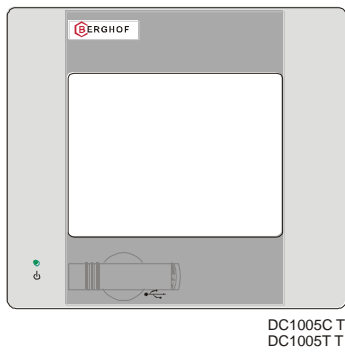
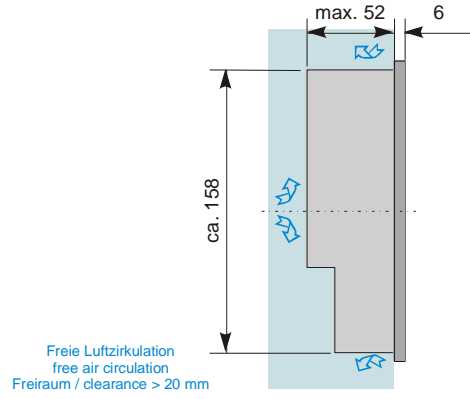
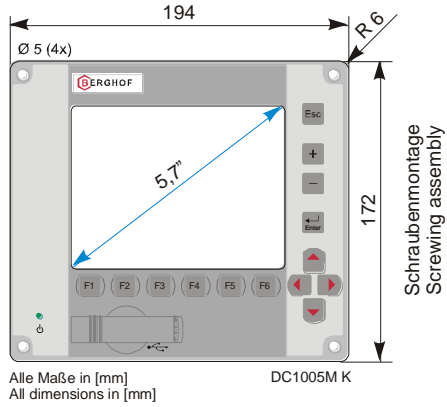

2VF100234DG03.cdr

2.4.4. DC1005 Panel cutout

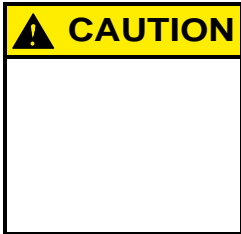

Installation instruction:
Only install the Dialog-Controller on a level surface!
 The support points on the Dialog-Controller may not deviate from one another by more than +/-0.5 mm. If the Dialog-Controller is nonetheless mounted on a base which is not level, mechanical tension can result in cracks in the front panel.

The Dialog-Controller is intended for front installation. A square panel cutout is required. The support material thickness may not exceed 6 mm. The panel cutouts are identical for units equipped with either a keyboard or a touchpad.

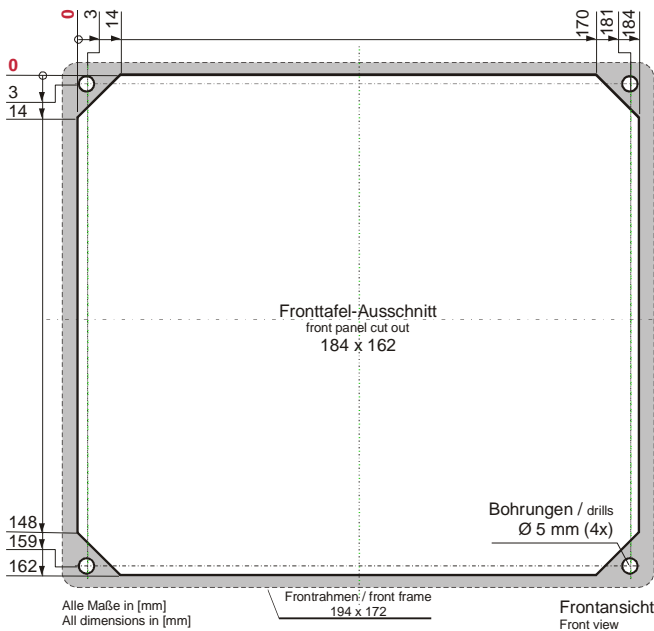

2VF100235DG00.cdr

2.4.5. Mounting regulation DC1005

The Dialog-Controllers are designed for automatic convection cooling.

The Dialog-Controllers must be mounted vertically onto a metallic mounting plate.

→ Vertical installation



Danger of overheating and fire!
 The Dialog-Controller may be destroyed even at a permissible ambient temperature if the convection cooling cannot function because it is built-in. It must therefore be installed vertically and the upper and lower housing apertures must not be covered over!

2.5. Technical data DC1010

Module data	
Display	
Diagonal measurement	10.4"
Resolution	640 x 480 pixels (VGA)
Colors	65536 (16 bit per pixel)
CPU, application memory	
CPU	Freescale PowerPC 400 MHz
Program memory (Flash)	32 MB onboard / 24 MB for application
Program memory and data memory (RAM)	128 MB onboard / 96 MB for application
Retain memory	16 kB
Development environment	CP1131 (CODESYS 2.3)
Dimensions and weights	
Dimensions (WxHxD [mm])	360x260x77 (+6 mm front panel)
Weight	Approx. 5 kg
Operating conditions	
Ambient temperature range	0 °C to +55 °C (if installation rule is adhered to)
Relative humidity	Max. 90 %, non-condensing
Transport, storage	
Ambient temperature range	-20 °C to +70 °C
Relative humidity	Max. 90 %, non-condensing
Shock resistance	
Vibration	Sinusoidal (EN 60068-2-6) test: Fc 10 ... 150 Hz, 1 G (operation mode)
Shock resistance	15 G (approx. 150 m/s ²); duration:10 ms; semi-sinusoidal (EN 60068-2-27) test: Ea
EMC, protection type	
Interference emission	EN 61000-6-4, industrial environments
Interference resistance	EN 61000-6-2, industrial environments
Protection class	III
Insulating resistance	EN 61131-2; DC 500 V test voltage
Protection type	IP20 (front: IP65)

Module data

Power supply (24 V power pack)

Supply voltage	+24 VDC (-15 % / +20 %) SELV, max. alternating component: 5 %, max. voltage interruption 1 ms (10 ms only with power supply after 61131-2)
Current consumption	Typically 1.0 A; max. 2.0 A at +24 VDC; Fusing depending on the I/O load, max. 12 A
Polarity reversal protection	Yes
Potential isolation	Yes, between CAN bus and I/Os.

Ethernet port

Number / interface type	1 x 10/100 Base-T
Connection method	RJ45

USB ports

Number / interface types	1 x host USB, Rev. 1.1 (on rear) 1 x host USB, Rev. 1.1 (on front, Prime Interface only)
Plug/unplug cycles	Max. 1,000

CAN bus ports

Number / interface types	2 x Standard CAN ISO 11898 Prime Interface 1 x Standard CAN ISO 11898 Basic Interface
Potential isolation	CAN0 (X6) potential isolated (Prime Interface only)
Transmission rate	Max. 1 Mbit/s
Terminating resistor	Switchable

Serial ports

Number / interface types	2 x RS232 Prime Interface / 1 x RS232 Basic Interface 1 x RS485
Potential isolation	RS485 (X8) potential isolated (Prime Interface only)
Terminating resistor	Switchable with the RS485

E-bus port

Interface type	I/O expansion bus for up to 7 E-bus subscribers
----------------	---

Expansion slots

Number / interface types	3 slots for 3 I/O modules or 2 I/O modules and one AnyBus® module (Prime Interface only)
--------------------------	--

Further features

Real-time clock	Yes, battery backed.
SD card	1 SD card slot or RS232 (X5) (Prime Interface only)

2.5.1. DC1010 Front view



2VF100241DG01.cdr

2.5.2. DC1010 Rear view

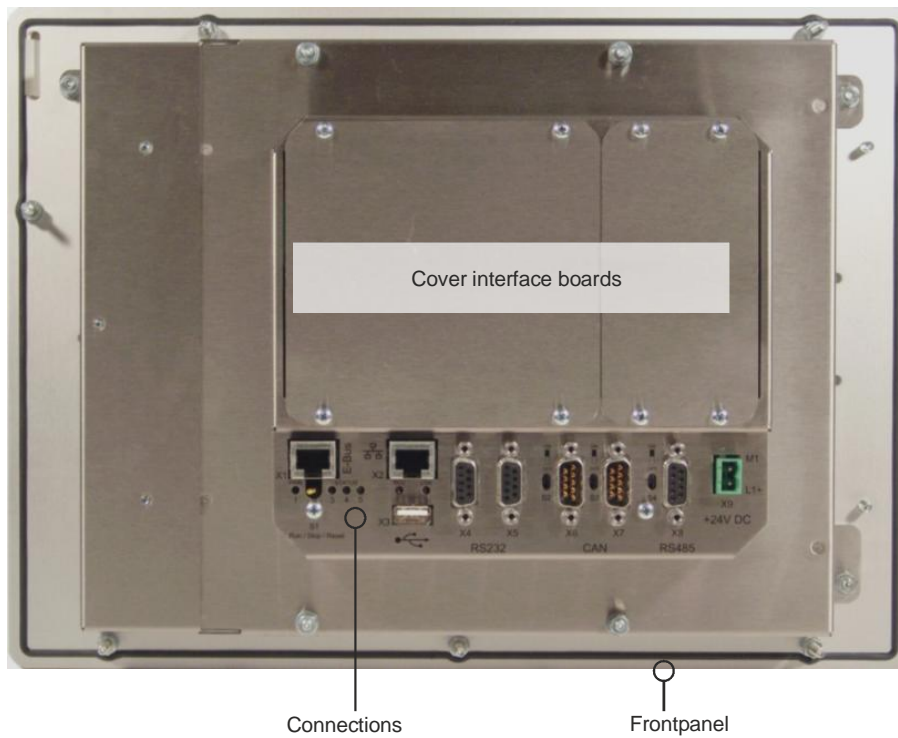

2VF100242DG01.cdr

2.5.3. DC1010 Dimensions

Dimensions are identical for units equipped with either a keyboard or a touchpad.

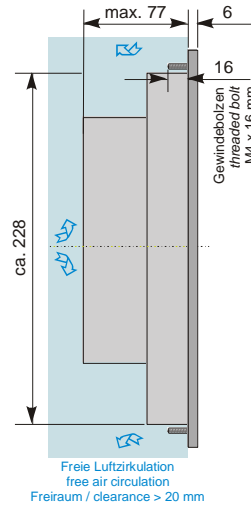
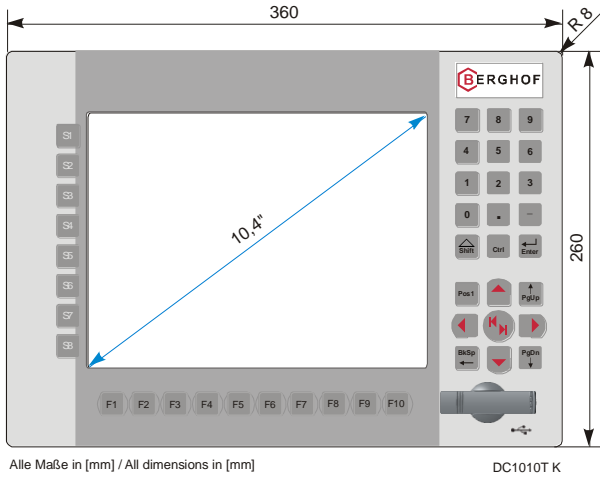

2VF100243DG01.cdr

2.5.4. DC1010 Panel cutout

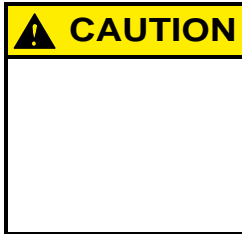

Installation instruction:
Only install the Dialog-Controller on a level surface!
 The support points on the Dialog-Controller may not deviate from one another by more than +/-0.5 mm. If the Dialog-Controller is nonetheless mounted on a base which is not level, mechanical tension can result in cracks in the front panel!

The Dialog-Controller is intended for front installation. A square panel cutout is required. The support material thickness may not exceed 6 mm. The panel cutouts are identical for units equipped with either a key-board or a touch panel.

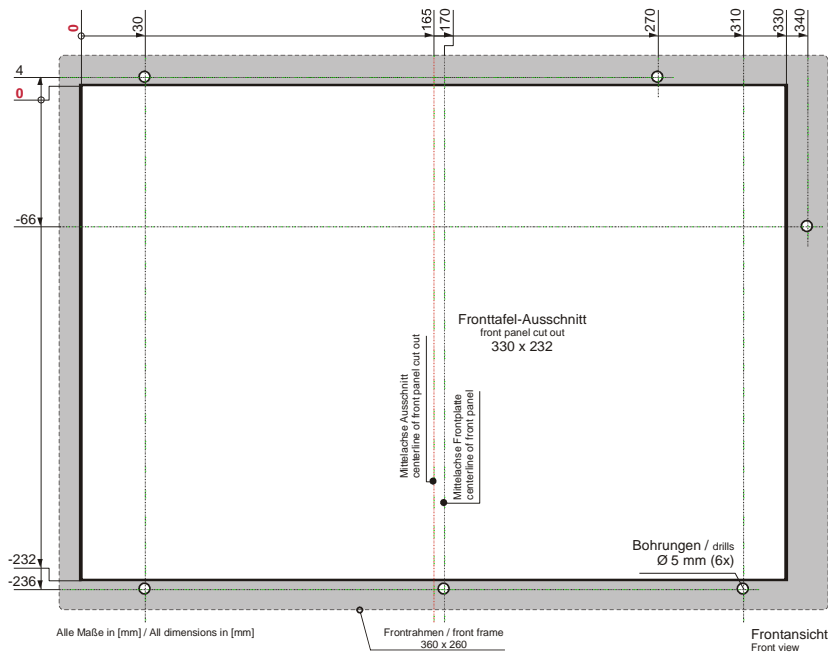

2VF100244DG00.cdr

2.5.5. Mounting regulation DC1010

The Dialog-Controllers are designed for automatic convection cooling.

→ Vertical installation

The Dialog-Controllers must be mounted vertically onto a metallic mounting plate.



Danger of overheating and fire!
 The Dialog-Controller may be destroyed even at a permissible ambient temperature if the convection cooling cannot function because it is built-in. It must therefore be installed vertically and the upper and lower housing apertures must not be covered over!

2.6. Technical data DC1010 Compact (CP)

Module data	
Display	
Diagonal measurement	10.4"
Resolution	640 x 480 pixels (VGA)
Colors	65536 (16 bit per pixel)
CPU, application memory	
CPU	Freescle PowerPC 400 MHz
Program memory (Flash)	32 MB onboard / 24 MB for application
Program memory and data memory (RAM)	128 MB onboard / 96 MB for application
Retain memory	16 kB
Development environment	CP1131 (CODESYS 2.3)
Dimensions and weights	
Dimensions (WxHxD [mm])	313x250x77 (+6 mm front panel)
Weight	Approx. 5 kg
Operating conditions	
Ambient temperature range	0 °C to +55 °C (if installation rule is adhered to)
Relative humidity	Max. 90 %, non-condensing
Transport, storage	
Ambient temperature range	-20 °C to +70 °C
Relative humidity	Max. 90 %, non-condensing
Shock resistance	
Vibration	Sinusoidal (EN 60068-2-6) test: Fc 10 ... 150 Hz, 1 G (operation mode)
Shock resistance	15 G (approx. 150 m/s ²); duration:10 ms; semi-sinusoidal (EN 60068-2-27) test: Ea
EMC, protection type	
Interference emission	EN 61000-6-4, industrial environments
Interference resistance	EN 61000-6-2, industrial environments
Protection class	III
Insulating resistance	EN 61131-2; DC 500 V test voltage
Protection type	IP20 (front: IP65)

Module data	
Power supply (24 V power pack)	
Supply voltage	+24 VDC (-15 % / +20 %) SELV, max. alternating component: 5 %, max. voltage interruption 1 ms (10 ms only with power supply after 61131-2)
Current consumption	Typically 1.0 A; max. 2.0 A at +24 VDC; Fusing depending on the I/O load, max. 12 A
Polarity reversal protection	Yes
Potential isolation	Yes, between CAN bus and I/Os.
Ethernet port	
Number / interface type	1 x 10/100 Base-T
Connection method	RJ45
USB ports	
Number / interface types	1 x host USB, Rev. 1.1 (on rear) 1 x host USB, Rev. 1.1 (on front, Prime Interface only)
Plug/unplug cycles	Max. 1,000
CAN bus ports	
Number / interface types	2 x Standard CAN ISO 11898 Prime Interface 1 x Standard CAN ISO 11898 Basic Interface
Potential isolation	CAN0 (X6) potential isolated (Prime Interface only)
Transmission rate	Max. 1 Mbit/s
Terminating resistor	Switchable
Serial ports	
Number / interface types	2 x RS232 Prime Interface / 1 x RS232 Basic Interface 1 x RS485
Potential isolation	RS485 (X8) potential isolated (Prime Interface only)
Terminating resistor	Switchable with the RS485
E-bus port	
Interface type	I/O expansion bus for up to 7 E-bus subscribers
Expansion slots	
Number / interface types	3 slots for 3 I/O modules or 2 I/O modules and one AnyBus [®] module (Prime Interface only)
Further features	
Real-time clock	Yes, battery backed.
SD card	1 SD card slot or RS232 (X5) (Prime Interface only)

2.6.1. DC1010 Compact (CP) front view

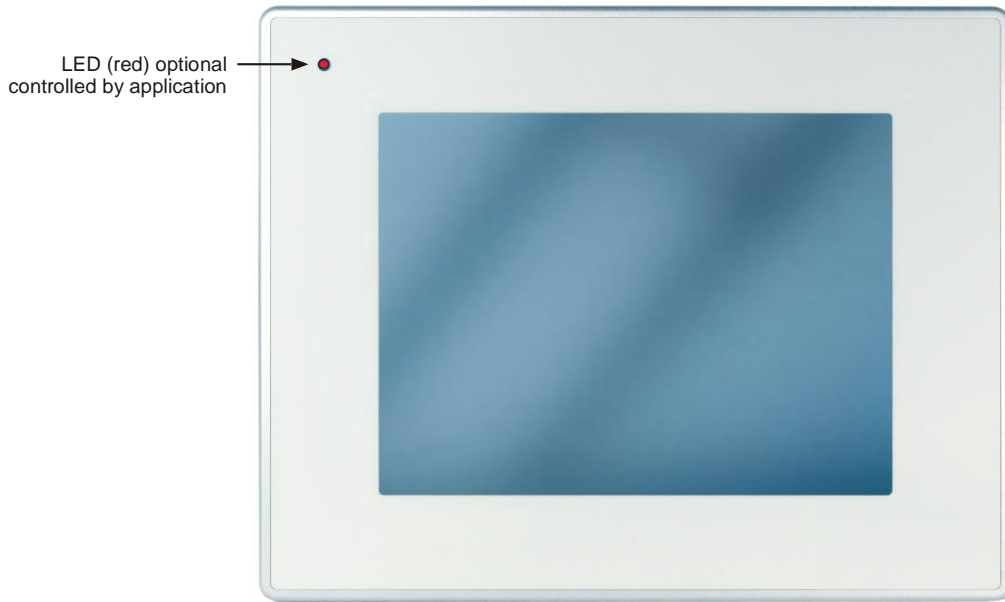

2VF100459DG00.cdr

2.6.2. DC1010 Compact (CP) rear view

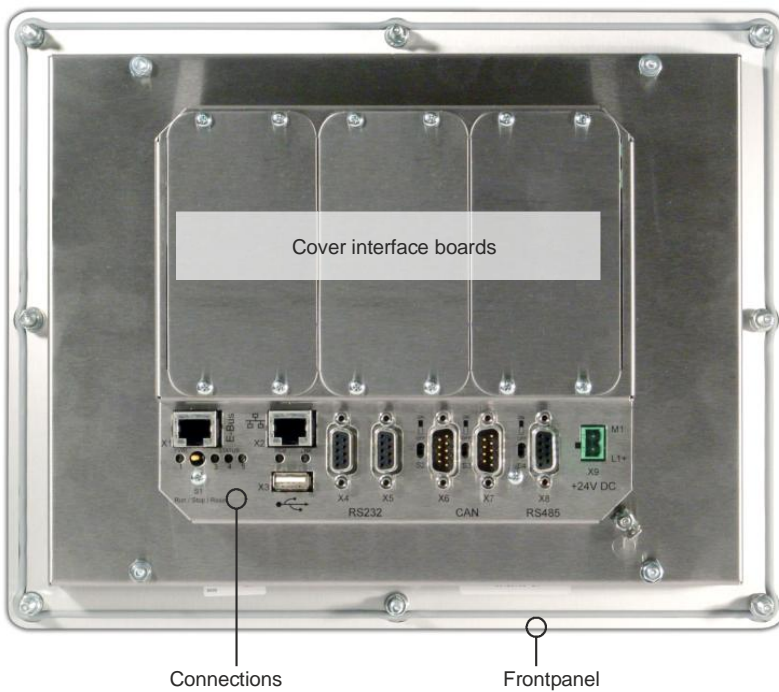

2VF100460DG01.cdr

2.6.3. DC1010 Compact (CP) dimensions

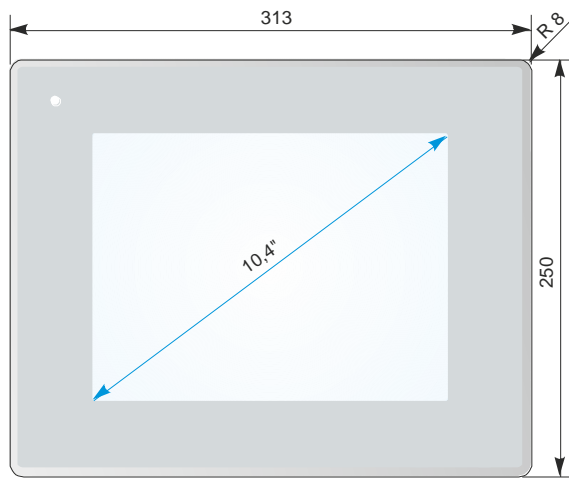

Alle Maße in [mm] / All dimensions in [mm]

DC1010T T

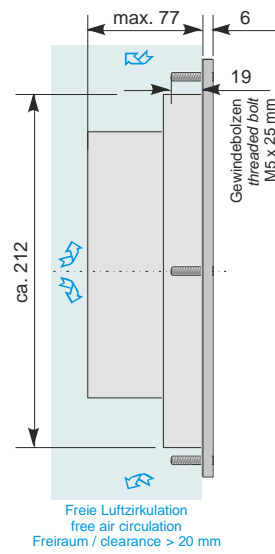

2VF100461DG00.cdr

2.7. Technical data DC1012

Module data	
Display	
Diagonal measurement	12.1"
Resolution	800 x 600 pixels (VGA)
Colors	65536 (16 bit per pixel)
CPU, application memory	
CPU	Freescale PowerPC 400 MHz
Program memory (Flash)	32 MB onboard / 24 MB for application
Program memory and data memory (RAM)	128 MB onboard / 96 MB for application
Retain memory	16 kB
Development environment	CP1131 (CODESYS 2.3)
Dimensions and weights	
Dimensions (WxHxD [mm])	440x300x77 (+6 mm front panel)
Weight	Approx. 6 kg
Operating conditions	
Ambient temperature range	0 °C to +55 °C (if installation rule is adhered to)
Relative humidity	Max. 90 %, non-condensing
Transport, storage	
Ambient temperature range	-20 °C to +70 °C
Relative humidity	Max. 90 %, non-condensing
Shock resistance	
Vibration	Sinusoidal (EN 60068-2-6) test: Fc 10 ... 150 Hz, 1 G (operation mode)
Shock resistance	15 G (approx. 150 m/s ²); duration:10 ms; semi-sinusoidal (EN 60068-2-27) test: Ea
EMC, protection type	
Interference emission	EN 61000-6-4, industrial environments
Interference resistance	EN 61000-6-2, industrial environments
Protection class	III
Insulating resistance	EN 61131-2; DC 500 V test voltage
Protection type	IP20 (front: IP65)

Module data

Power supply (24 V power pack)

Supply voltage	+24 VDC (-15 % / +20 %) SELV, max. alternating component: 5 %, max. voltage interruption 1 ms (10 ms only with power supply after 61131-2)
----------------	--

Current consumption	Typically 1.0 A; max. 2.0 A at +24 VDC; Fusing depending on the I/O load, max. 12 A
---------------------	--

Polarity reversal protection	Yes
------------------------------	-----

Potential isolation	Yes, between CAN bus and I/Os.
---------------------	--------------------------------

Ethernet port

Number / interface type	1 x 10/100 Base-T
-------------------------	-------------------

Connection method	RJ45
-------------------	------

USB ports

Number / interface types	1 x host USB, Rev. 1.1 (on rear) 2 x host USB, Rev. 1.1 (on front)
--------------------------	---

Plug/unplug cycles	Max. 1,000
--------------------	------------

CAN bus ports

Number / interface types	2 x Standard CAN ISO 11898
--------------------------	----------------------------

Potential isolation	CAN0 (X6) potential isolated
---------------------	------------------------------

Transmission rate	Max. 1 Mbit/s
-------------------	---------------

Terminating resistor	Switchable
----------------------	------------

Serial ports

Number / interface types	2 x RS232 1 x RS485
--------------------------	------------------------

Potential isolation	RS485 (X8) potential isolated
---------------------	-------------------------------

Terminating resistor	Switchable with the RS485
----------------------	---------------------------

E-bus port

Interface type	I/O expansion bus for up to 7 E-bus subscribers
----------------	---

Expansion slots

Number / interface types	3 slots for 3 I/O modules or 2 I/O modules and one AnyBus® module
--------------------------	---

Further features

Real-time clock	Yes, battery backed.
-----------------	----------------------

SD card	1 SD card slot or RS232 (X5)
---------	------------------------------

2.7.1. DC1012 Front view



2VF100272DG01.cdr

2.7.2. DC1012 Rear view

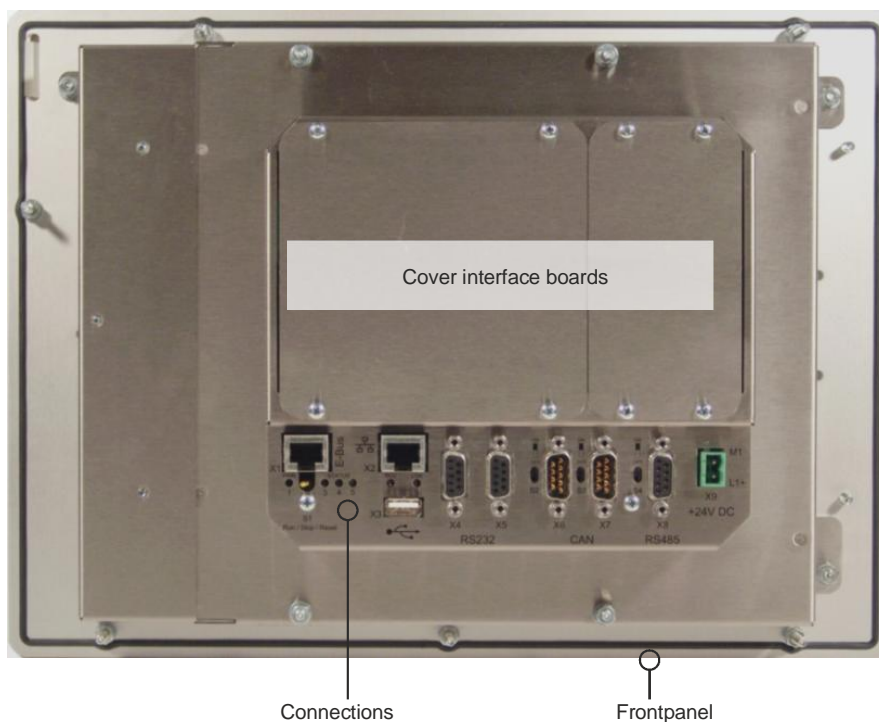

2VF100242DG01.cdr

2.7.3. DC1012 Dimensions

Dimensions are identical for units equipped with either a keyboard or a touchpad.

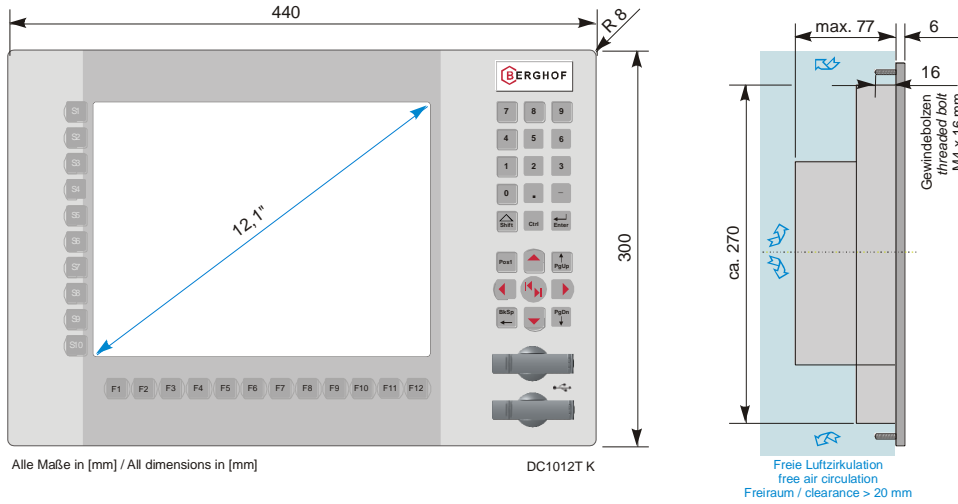

2VF100270DG01.cdr

2.7.4. DC1012 Panel cutout

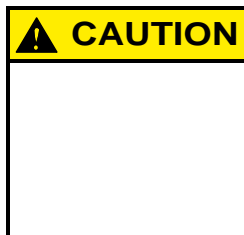

Installation instruction:
Only install the Dialog-Controller on a level surface!
 The support points on the Dialog-Controller may not deviate from one another by more than +/-0.5 mm. If the Dialog-Controller is nonetheless mounted on a base which is not level, mechanical tension can result in cracks in the front panel!

The Dialog-Controller is intended for front installation. A square panel cutout is required. The support material thickness may not exceed 6 mm. The panel cutouts are identical for units equipped with either a key-board or a touch panel.

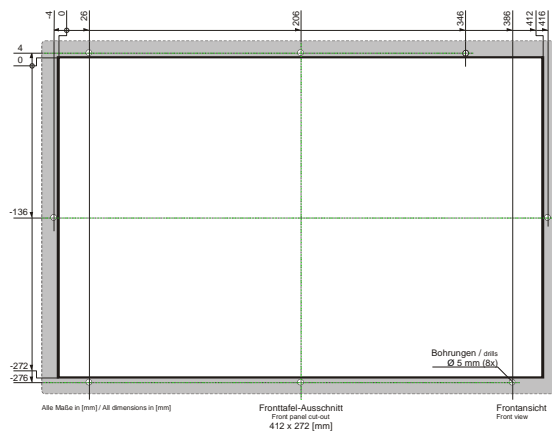

2VF100271DG00.cdr

2.7.5. Mounting regulation DC1012

The Dialog-Controllers are designed for automatic convection cooling.

→ Vertical installation

The Dialog-Controllers must be mounted vertically onto a metallic mounting plate.



Danger of overheating and fire!
 The Dialog-Controller may be destroyed even at a permissible ambient temperature if the convection cooling cannot function because it is built-in. It must therefore be installed vertically and the upper and lower housing apertures must not be covered over!

2.8. Technical data DC1012 Compact (CP)

Module data	
Display	
Diagonal measurement	12.1"
Resolution	800 x 600 pixels (VGA)
Colors	65536 (16 bit per pixel)
CPU, application memory	
CPU	Freescale PowerPC 400 MHz
Program memory (Flash)	32 MB onboard / 24 MB for application
Program memory and data memory (RAM)	128 MB onboard / 96 MB for application
Retain memory	16 kB
Development environment	CP1131 (CODESYS 2.3)
Dimensions and weights	
Dimensions (WxHxD [mm])	360x260x77 (+6 mm front panel)
Weight	Approx. 6 kg
Operating conditions	
Ambient temperature range	0 °C to +55 °C (if installation rule is adhered to)
Relative humidity	Max. 90 %, non-condensing
Transport, storage	
Ambient temperature range	-20 °C to +70 °C
Relative humidity	Max. 90 %, non-condensing
Shock resistance	
Vibration	Sinusoidal (EN 60068-2-6) test: Fc 10 ... 150 Hz, 1 G (operation mode)
Shock resistance	15 G (approx. 150 m/s ²); duration:10 ms; semi-sinusoidal (EN 60068-2-27) test: Ea
EMC, protection type	
Interference emission	EN 61000-6-4, industrial environments
Interference resistance	EN 61000-6-2, industrial environments
Protection class	III
Insulating resistance	EN 61131-2; DC 500 V test voltage
Protection type	IP20 (front: IP65)

Module data	
Power supply (24 V power pack)	
Supply voltage	+24 VDC (-15 % / +20 %) SELV, max. alternating component: 5 %, max. voltage interruption 1 ms (10 ms only with power supply after 61131-2)
Current consumption	Typically 1.0 A; max. 2.0 A at +24 VDC; Fusing depending on the I/O load, max. 12 A
Polarity reversal protection	Yes
Potential isolation	Yes, between CAN bus and I/Os.
Ethernet port	
Number / interface type	1 x 10/100 Base-T
Connection method	RJ45
USB ports	
Number / interface types	1 x host USB, Rev. 1.1 (on rear)
Plug/unplug cycles	Max. 1,000
CAN bus ports	
Number / interface types	2 x Standard CAN ISO 11898
Potential isolation	CAN0 (X6) potential isolated
Transmission rate	Max. 1 Mbit/s
Terminating resistor	Switchable
Serial ports	
Number / interface types	2 x RS232 1 x RS485
Potential isolation	RS485 (X8) potential isolated
Terminating resistor	Switchable with the RS485
E-bus port	
Interface type	I/O expansion bus for up to 7 E-bus subscribers
Expansion slots	
Number / interface types	3 slots for 3 I/O modules or 2 I/O modules and one AnyBus® module
Further features	
Real-time clock	Yes, battery backed.
SD card	1 SD card slot or RS232 (X5)

2.8.1. DC1012 Compact (CP) front view



2VF100473DG01.cdr

2.8.2. DC1012 Compact (CP) rear view

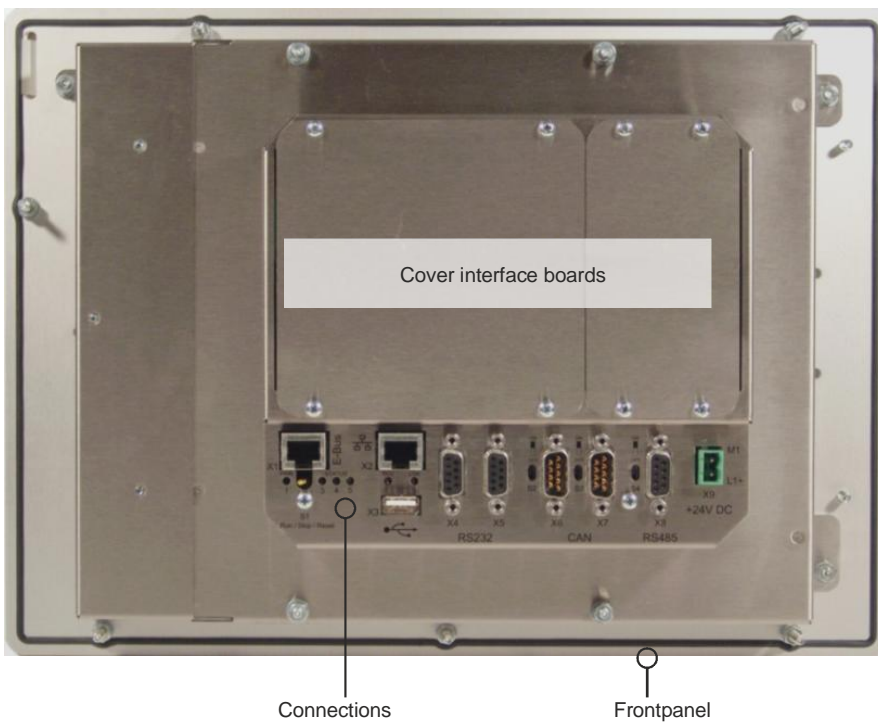

2VF100242DG01.cdr

2.8.3. DC1012 Compact (CP) dimensions

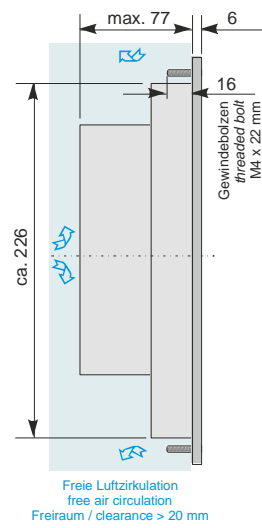
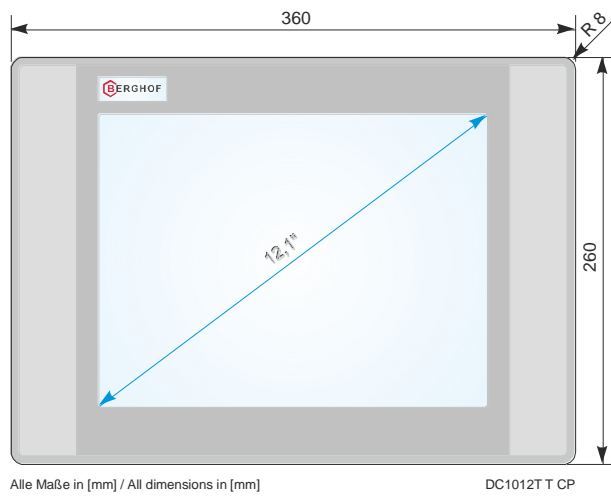

2VF100474DG00.cdr

2.8.4. DC1012 Compact (CP) panel cutout

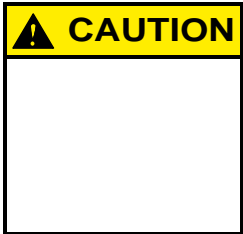

Installation instruction:
Only install the Dialog-Controller on a level surface!
 The support points on the Dialog-Controller may not deviate from one another by more than +/-0.5 mm. If the Dialog-Controller is nonetheless mounted on a base which is not level, mechanical tension can result in cracks in the front panel!

The Dialog-Controller is intended for front installation. A square panel cutout is required. The support material thickness may not exceed 6 mm.

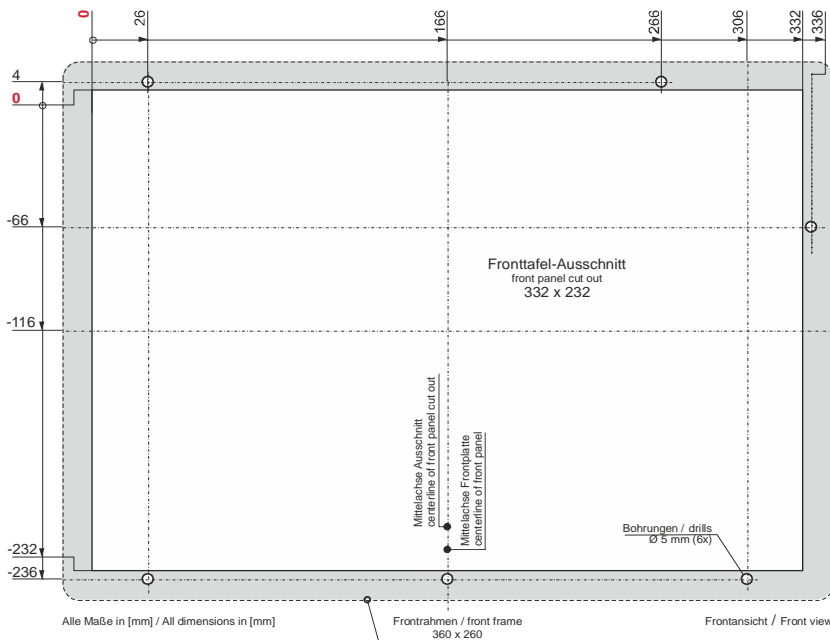

2VF100475DG00.cdr

2.8.5. Mounting regulation DC1012 Compact (CP)

The Dialog-Controllers are designed for automatic convection cooling.

The Dialog-Controllers must be mounted vertically onto a metallic mounting plate.

→ Vertical installation



Danger of overheating and fire!
 The Dialog-Controller may be destroyed even at a permissible ambient temperature if the convection cooling cannot function because it is built-in. It must therefore be installed vertically and the upper and lower housing apertures must not be covered over!

2.9. Mounting and connection

2.9.1. Mounting

Required tools

Box wrench, Allan key (7 mm) or open-end wrench SW

Securing

The Dialog-Controller is equipped with approx. 15 mm-long, M 4, welded-on stud bolts. The unit is secured using U washers, spring washers/lock washers and nuts (M 4).

- Remove the shipping nuts and washers.
- Push the Dialog-Controller through the panel cutout.
- Secure the Dialog-Controller in the panel cutout.
- Adjust the Dialog-Controller in the panel cutout and tighten all nuts.



Disassembly:
Follow the reverse sequence to disassemble the Dialog-Controller.

2.9.2. Connections

Power supply

Power for the Dialog-Controller comes from an external 24 VDC power supply. Before continuing with the connection, check that the external power supply meets the required specifications.

External power supply (24 VDC)	
Output voltage	+24 VDC SELV (-15 % / +20 %)
Alternating component	Max. 5 %. The direct voltage level may not fall below 20.4 V.
Power output	Max. 2.0 A at +24 VDC at 25 °C.

Installation

All connections and wiring must be laid out to prevent any interference due to inductive or capacitive pick-up from arising in the Dialog-Controller. The infeed lines must provide adequate current and voltage carrying capacity.

→ Ground

Connect the Dialog-Controller's housing to the ground lead (PE) with a copper cross-section of at least 1.5 mm².

The Dialog-Controller is equipped with a 6.3 x 0.8 mm plug-in tab for this purpose.



2VF100236DG00.cdr

2.10. Pin assignment

2.10.1. Pin overview



2VF100231DG00.cdr

2.10.2. Power supply

Internal power pack

A power pack to provide 24 VDC (-15 % / +20 %) input voltage is built into the Dialog-Controller. The power pack is equipped with internal polarity reversal protection and a current at make limiter. The infeed line and the power pack must be protected by means of an external short circuit and overload protector with a maximum of 12 A (depending on the number of I/Os).

Power buffering

The power supply unit can bridge voltage dips lasting 1 ms maximum.

X9 pin assignment

X9		
1	+	external power supply 24 VDC (-15 % / +20 %)
2	-	external power supply GND
Phoenix MSTB 2.5/2-G-5.08		

2.10.3. 10/100 Base-T Network Connection (Ethernet)

The onboard 10/100 Base-T Ethernet adapter with an RJ45 connector is used to connect the unit to a network. The “LNK” and “RCV” status LEDs provide information regarding a successful network link.

X2 pin assignment

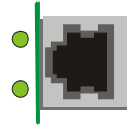
X2		
 RJ45	1	TX+
	2	TX-
	3	RX+
	4	75 Ω
	5	75 Ω
	6	RX-
	7	75 Ω
	8	75 Ω
“LNK” LED	green	ON – operational
“RCV” LED	green	FLASHING – data receive

2.10.4. USB

Devices equipped with USB interfaces can be connected to the two USB master ports (Rev. 1.1). The USB on the back (X3) and the front USB (under the IP65 cover) are connected via an internal USB hub. The only USB devices classes which can be employed for CODESYS users are USB sticks. A mouse can only be employed at the Linux level. The following points must be taken into consideration when USB sticks are employed:

 CAUTION	<p>An USB stick may only be pulled during operation if all file operations have been completed, otherwise the USB stick may become unusable!</p> <p>If programs still have files open, the directory will no longer be able to be removed once the USB stick has been pulled. In this situation file or directory operations will result in blockages because information is to be read from a device that is no longer available in the system. Therefore, always make sure that no program still has open files in the USB stick before pulling the stick.</p>
--	---

- USB memory sticks with FAT/FAT32 formatting are supported.
- USB memory sticks can be inserted and pulled during operation. The inserted device is automatically detected and mounted in the /media/usbX directory. When the USB stick is pulled, the associated /media/usbX directory automatically “disappears” provided no program is currently accessing it (see above).
- Either the first partition or, if there are no partitions, the entire memory will be mounted on the memory stick, in other words, the associated directory appears automatically.
- The first stick is mounted under /media/usb0, the second under /media/usb1, and so on. A maximum of 8 sticks may be inserted simultaneously (/media/usb[0-7]). If a new (or previously inserted, then pulled) stick is inserted it will be placed on the directory with the lowest number. Connecting a USB hub allows multiple sticks to be operated at a given USB interface. Care must be taken that no USB devices are still inserted in the hub when the hub is itself inserted or pulled.
- Based on the variety and number of available USB chip and USB drive manufactures, there is no guarantee that every available USB drive on the market works with the device. Every USB drive has to be

checked if it works with the desired controller in advance. It is also recommended to use always the newest available firmware to get the best possible results.



The mechanical structure of the USB port is designed for a maximum of 1,000 insertion cycles.

X3 pin assignment

→ identical for the front USB

X3		
 USB	B1	VCC
	B2	D-
	B3	D+
	B4	GND



A maximum current of 0.5 A is available at the USB ports (combined)!
 A device requiring more current will therefore not function and may be damaged.

2.10.5. CAN bus

The two CAN ports (CAN0/CAN1) comply with the ISO 11898 standard and can be operated up to a maximum baud rate of 1 MBit/s. The smallest CAN baud rate that can be set is 50 kBit/s. In addition, the X6 interface (CAN0) is equipped with a potential isolation.

X6/7 pin assignment

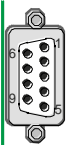
X6/7		
 Sub-D9 M	1	NC (Do not connect)
	2	CAN_L
	3	CAN_GND
	4	NC (Do not connect)
	5	NC (Do not connect)
	6	NC (Do not connect)
	7	CAN_H
	8	NC (Do not connect)
	9	NC (Do not connect)



A terminating resistor can be switched using the S2 (CAN0) and S3 (CAN1) switches.
 This is required if the associated CAN interface is located at the beginning or at the end of its CAN bus topology.

2.10.6. Serial ports

In all, the module is equipped with 3 serial communications interfaces, each of which is connected using a 9-pin Sub-D socket. X8 is a potential isolated RS485 interface, while two RS232 ports are available at X4/X5.

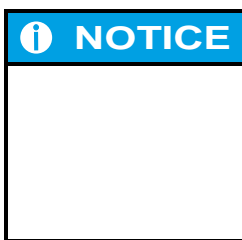

The RS232 port at X4 has an exception setting!
 Depending on the configuration it can be used as either a Linux console, or as a PPP interface for remote maintenance or a CODESYS programming interface.
 If the Dialog-Controller is started in the configuration mode, the device can be configured in this mode using a serial PPP link. Here too, connection is via X4.

The interfaces in the software are addressed by the following names:

Connector	Software interface
X4	COM1
X5	COM2
X6	COM3

→ [RS232](#)

X4/5 pin assignment

X4/5	
 Sub-D9 F	1 NC (Do not connect)
	2 RXD
	3 TXD
	4 NC (Do not connect)
	5 GND
	6 NC (Do not connect)
	7 NC (Do not connect)
	8 NC (Do not connect)
	9 NC (Do not connect)



If the SD card reader is activated, then the second RS232 interface (X5) is not longer available.

X8 pin assignment

→ [RS485 potential isolated](#)

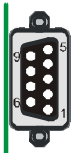
X8		
 <p>Sub-D9 F</p>	1	RTXD-
	2	NC (Do not connect)
	3	NC (Do not connect)
	4	RTXD+
	5	GND
	6	NC (Do not connect)
	7	NC (Do not connect)
	8	NC (Do not connect)
	9	NC (Do not connect)

The interface is terminated “softly” in the Dialog-Controller at 500 Ω (older devices 5 kΩ). A 120 Ω differential terminating resistor can be activated for each S4 switch.

i NOTICE

For using the symmetrical terminating resistor (S4) on the inoperative bus:

On an inoperative bus the terminating resistor causes a qualitatively unstable signal state, which can give rise to faulty received data.

Background information:

Thanks to the differential signal transmission the RS485 interface achieves a high signal-to-noise ratio and facilitates high data rates and great ranges. An operative bus with defined states - logical '1' ($A-B < -0.2 \text{ V}$) or logical '0' ($A-B > +0.2 \text{ V}$) - is prerequisite for a high symmetrical signal-to-noise ratio. In an inoperative bus the signals highly resistive and hence susceptible to interference. Thanks to the terminating resistor, which can be activated, a signal state is produced with a low voltage difference between lines A and B.

There are two measures which can prevent this state:

- An appropriate log ensures that one of the bus subscribers operates the bus actively at all times.
- If the state of the inoperative bus is to be kept under control, a sufficient signal-to-noise ratio must be established by means of an asymmetric bus termination (at the same time reducing the symmetrical signal-to-noise ratio). With a suitable resistance network as the line termination, a voltage difference between the signals can be produced in an inoperative state. Generally speaking, it is impossible to specify favorable dimensioning because it is affected by the length of the bus and transmission rates. By way of example, reference is made to the line termination in the case of the Profibus.

i NOTICE

How to connect "GND":

Despite differential signal transmission, depending on the topology and length of the connected lines, it may be imperative to connect ground reference (GND) may be imperative!

The longer the line the greater the potential differences between bus subscribers may be. In such cases, despite potential isolation, common-mode interference may exceed voltage limits, causing differential signal interference and hence a functional disorder. It is urgently advised to carry along the "GND" signal for potentially isolated interfaces, with a connection to the reference ground in one spot. An attenuating connection, for example via 200Ω at multiple points on the bus.

2.10.7. E-bus

The E-bus (X1) allows up to 7 E-bus subscribers to be connected to the Dialog-Controller. Please note that, due to their function, some E-bus modules represent 2 E-bus subscribers, e.g., QDIO-E 16/16/Z2.

Cable	
Type	Ethernet patch cable; 1:1 assignment (not crossed)
Lead cross-section	At least 0.22 mm ²
Category	CAT.5
Length	Max. 7 m

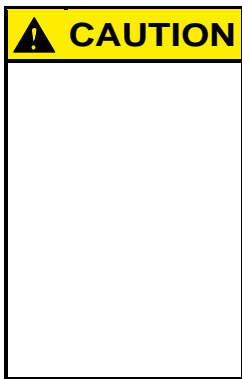

The Dialog-Controller makes a max. current of 0.5 A available for E-bus modules!

As a rule, this is sufficient current to supply 7 E-bus modules. However, should this current consumption level be exceeded, the E-bus and the connected modules may become nonfunctioning!

Therefore, please note the current consumption of all E-bus modules and all connected consumers as a whole. In some instances, connection of consuming devices, e.g., an encoder can result in the current limit being exceeded.

Wherever possible you should only employ consumer devices with as low a current requirement as possible!

2.10.8. Connections for expansion ports



Device connection

Prior to connecting any external devices, please carefully read the documentation included with these devices.

Always hold a lead by the plug when connecting or disconnecting a device. Never pull on the lead itself!

The connection level for all external devices is located on the rear of the Dialog-Controller. All connections are plug-in.

2.11. SD card



The SD card must not be plugged in or unplugged while the Dialog-Controller is operating as this would result in functional errors with the Dialog-Controller!

The SD card may only be installed or removed when the Dialog-Controller has been switched off!

The SD card drive is equipped with a push-in/push-out insert and eject mechanism. Gold plated contacts ensure low contact resistance and a service life of up to 10,000 plug-in/unplug cycles.

The write protection switch on the SD card is currently not recognized.

The SD card drive must be activated via the web configuration. In this case the application can no longer access the second serial port (SIO2/X5). The files on the SD drive can be written to, read from as well as copied. Access to the drive is along the following path: /media/sd.

At present data memory cards with a memory capacity of up to 1 GB can be used.



2VF100312DG01.cdr



If the SD card reader is activated, then the second RS232 interface (X5) is not longer available.

3. Dialog-Controller operation



Never plug in, apply, disconnect or touch connections while the device is operating!

This could result in malfunction or destruction of the device. Before working on the modules, always switch all infeeds to them off; including infeeds from connected peripheral devices such as remote-feed encoders, programming devices, etc.

3.1. Commissioning

Before applying the supply voltage, recheck all connections to ensure they are properly wired and have the correct polarity.

Switching on

The Dialog-Controller is not equipped with its own main power switch. The Dialog-Controller starts when the associated equipment is switched on or when the power supply is connected.

Switching off

The Dialog-Controller switches off when the associated equipment is switched off or the power supply is disconnected.

3.2. Function selection, indicators, diagnostics

3.2.1. Status indicators

The function of the status indicators frequently depends on the software development environment employed on the Dialog-Controller.

- **CP1131-P:** PLC programming using CODESYS and Berghof Target Support Package
- **CPC++:** C programming directly on the LINUX operating system

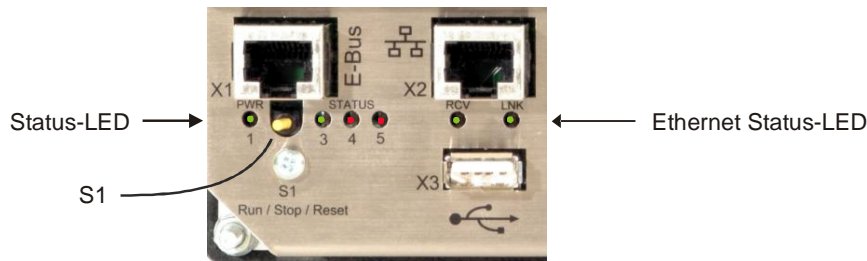

2VF100232DG00.cdr

Operating mode selection switch (S1)

Used to change the operating mode and for module restart.

Switch position	CP1131-P	CPC++
RUN	CP1131-P program in the RUN mode. Can be changed with the programming device.	Freely programmable
STOP	CP1131-P program in the STOP mode.	Freely programmable
RESET	CP1131-P program is restarted with deleted variables (RETAIN variables are not deleted).	Freely programmable

Status LED

Four operating status LEDs provide information about the current status of the power supply, the module mode as well as fault and error messages.

LED	Logical state	
1	PWR (green)	ON = Correct supply voltage to the module electronics

Status LEDs for CP1131-P programs			
Status 3 (green)	Status 4 (red)	Status 5 (red)	Description
on	off	any	Application program status: RUN
off	on	any	Application program status: STOP
off	flashing	any	Application program status: ERROR STOP
flashing	on	any	Application program status: Breakpoint STOP
any	any	on	CP1131 mode: FORCE

Basic recovery procedure in case of an ERROR STOP:

- determine the cause of the error (indicated in the service menu on the display or can be read using a web browser)
- correct the cause of the error
- perform a controller reset; or alternatively: Mode selection switch / Service menu / CODESYS/ web browser
- return the controller to operation



CP1131-P FORCE mode:
 FORCE indicates that the application program is running and CODESYS forces a value to be written to at least one variable at the start of every cycle. This makes it evident to the user that the application program might react differently if no such forced access to the PLC program's process were to occur.

Status LEDs for CPC++ programs

LEDs 3 to 5 can each be separately controlled by application software.

Ethernet status LED

Refer to the section “10/100 Base T Network Connection (Ethernet)”.

3.3. Service menu

Functional scope

The Dialog-Controller’s service menu allows the user to define and examine device and communications parameters as well as device states. It also represents a valuable service and commissioning aid. The service menu thus permits setting definition at the Ethernet interface and diagnostics functions in case of errors to be simplified and accelerated.

The service menu has a two-part structure:

→ [Basic structure](#)

Parameter window

The following four menu items are displayed here. Each menu item can contain additional subject-related submenu items.

- Config
- PLC
- Info
- Display

PLC window

Up to two lines reflecting the current PLC status can be displayed. Line 1 will always be visible, while line 2 will only appear when an error occurs.

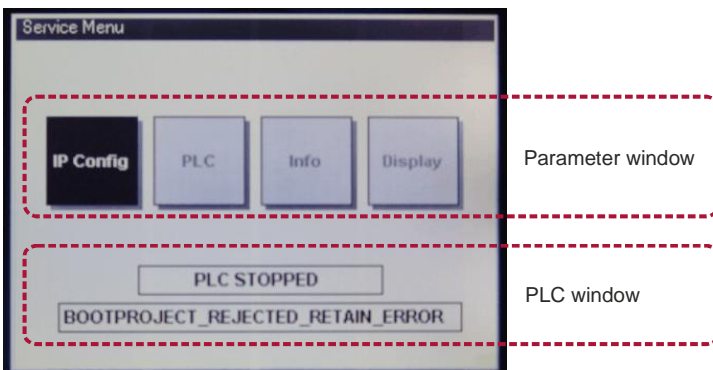

2VF100273DG01.cdr

3.3.1. Using the service menu

Touch screen

In Dialog-Controllers with a built-in touch screen, the service menu can be operated directly via screen input.

Keyboard

If the Dialog-Controller is equipped with a keyboard, the following keys are used to operate the service menu:

→ [Cursor block](#)

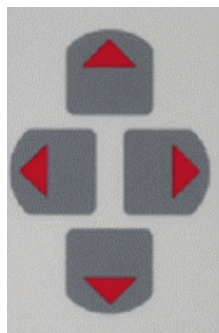

The cursor block is used to navigate between the individual menu items on a given menu level.

→ [\[Enter\] key](#)



The [Enter] key is used to confirm an input. If a submenu permits values to be modified, this modification is performed with the [Enter] key. The [+]/[-] keys do not function in the service menu. However, using the cursor block, you can navigate to a “+/-” symbol displayed on the screen, then use the [Enter] key to either increment or decrement the associated value.

→ [\[Esc\] key](#)



The [Esc] key is used to exit a menu without saving any changes which may have been made.

3.3.2. Parameter window

→ [Parameter window structure](#)

Checking and setting options are accessed through this window section.

The following four menu items are available for selection:

- **Config** to check and adjust Ethernet parameters, system time and the COM1 serial interface (X4).
- **PLC** to check and operate the PLC.
- **Info** to display the hardware and software version levels as well as diagnostic data; and it also offers the save function (USB, SD, Flash).
- **Display** to adjust contrast values.

“Config” service menu

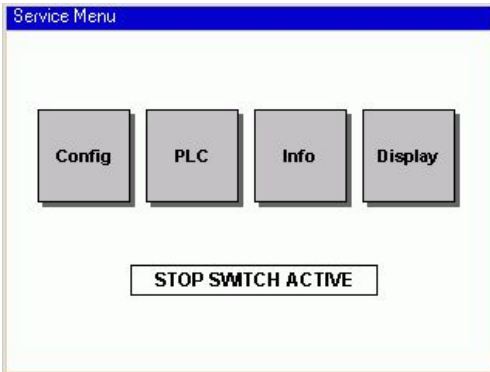

Check and adjust the parameters.

→ [Config](#)

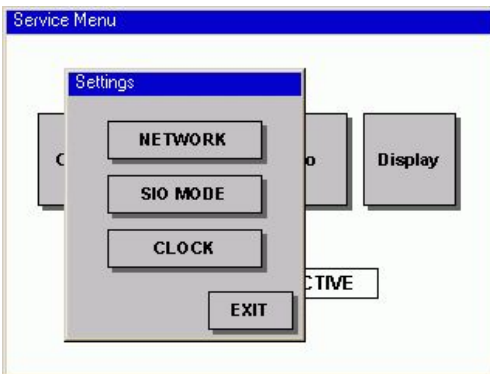

Check and adjust Ethernet parameters.

→ [NETWORK](#)

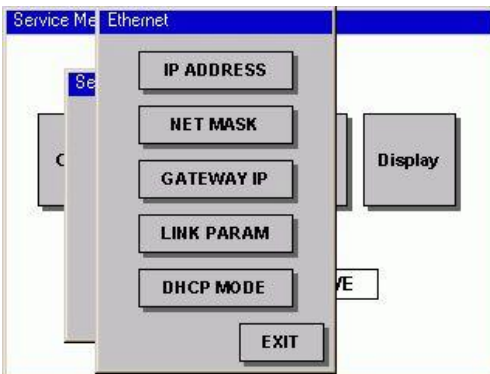

Check and adjust the IP address.

→ [Ethernet](#)
“IP ADDRESS”

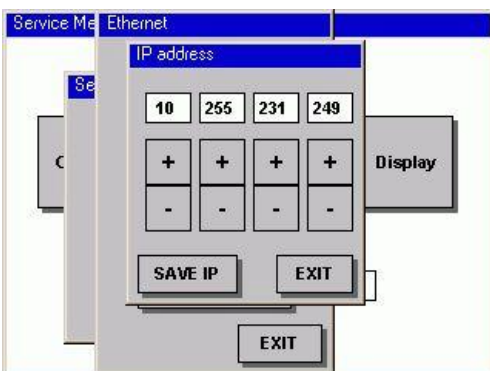

IP address:

The “+/-” keys can be used to adjust and set each individual IP address byte. The “**Save IP**” button is then used to save the settings. New settings will only take effect after a restart! The “**EXIT**” button allows you to leave the menu without saving any changes which may have been made.

→ Ethernet
"Net mask"

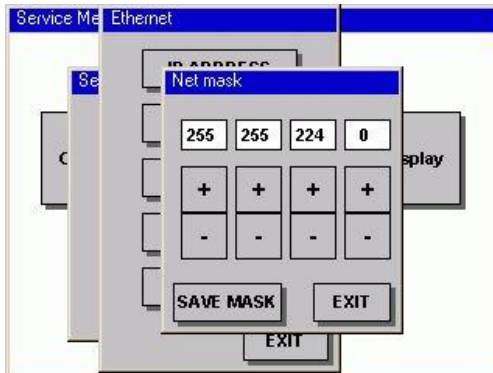

Check and adjust the network mask.

Net mask:

The "+/-" keys can be used to adjust and set each individual network mask byte. The "**Save Mask**" button is then used to save the settings. New settings will only take effect after a restart! The "**EXIT**" button allows you to leave the menu without saving any changes which may have been made.

→ Ethernet
"Gateway IP"

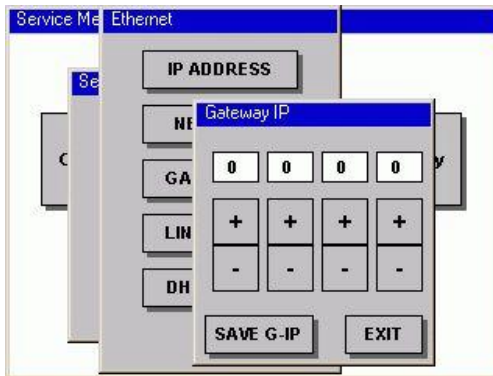

Check and adjust the gateway IP address.

Gateway IP:

The "+/-" keys can be used to adjust and set each individual gateway IP address byte. The "**Save G-IP**" button is then used to save the settings. New settings will only take effect after a restart! The "**EXIT**" button allows you to leave the menu without saving any changes which may have been made.

→ Ethernet
"LINK PARAM"

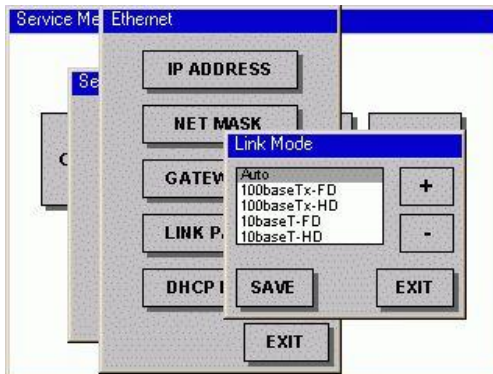

Check and adjust the communications parameters.

Link Mode:

Auto: Automatic parameter setting negotiated among the communications parameters (default setting). The default settings should only be changed under special circumstances (e.g. communications problems).

100base-Tx-FD: 100 MBit/s, full duplex

100base-Tx-HD: 100 MBit/s, half duplex

10base-T-FD: 10 MBit/s, full duplex

10base-T-HD: 10 MBit/s, half duplex

The "**Save**" button is used to save the new setting. New settings will only take effect after a restart! The "**EXIT**" button allows you to leave the menu without saving any changes which may have been made.

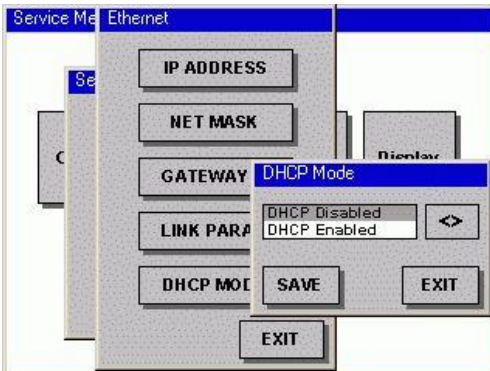

DHCP Mode:

Disabled: The IP ADDRESS set on the Dialog-Controller is valid.

Enabled: The IP ADDRESS is automatically retrieved from a DHCP server.

Caution: If DHCP is enabled, and there is no DHCP server available, the Controller will not boot! The Controller waits for a DHCP to allocate a valid IP address to it. If no DHCP server is present, the Dialog-Controller can only boot if the DHCP disabled setting has been configured. For this purpose the device must be put into configuration mode and can be converted via COM1 (X4) by means of web configuration (see manual: CP1131-P introduction).

→ Ethernet
"DHCP Mode"

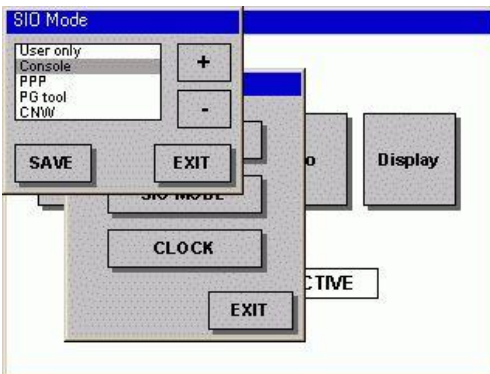

Setting the COM1(X4) serial interface.

User only: COM1 is available for CODESYS application

Console: Debug outputs of the operating system

PPP: TCP/IP over PPP protocol

PG Tool: CODESYS can upload and debug serial programs

CNW: reserved

→ SIO MODE
"SIO MODE"

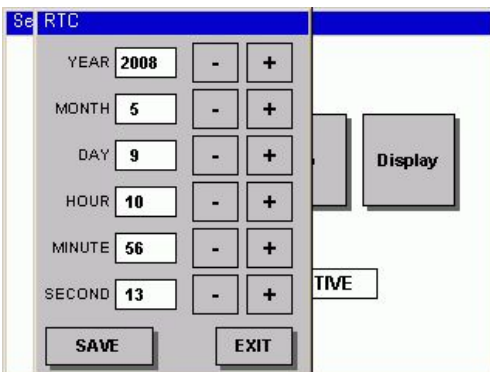

RTC: Setting the battery-buffered realtime clock.

→ CLOCK "RTC"

“PLC” service menu

→ PLC

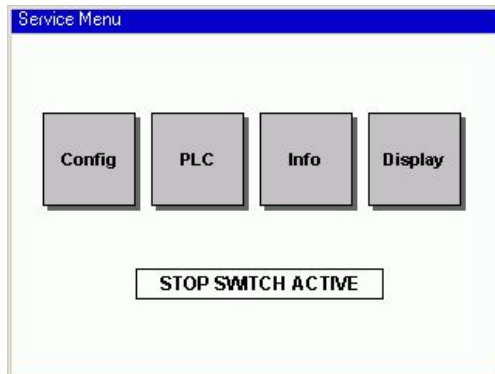

Change the PLC state.

→ PLC

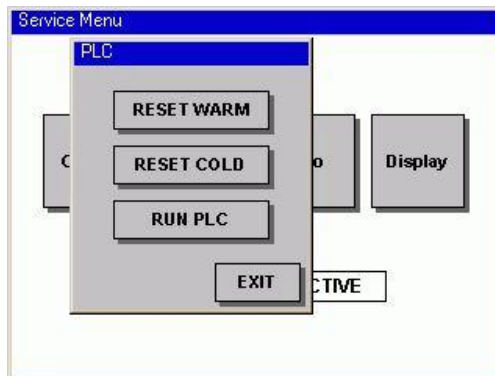

RESET WARM: After an error occurs the PLC program can be reset. With the exception of the RETAIN variables, all variables can be reset.

RESET COLD: After an error occurs the PLC program can be reset. With the exception of the RETAIN variables, all of the variables are reset, including the RETAIN variables.

RUN PLC: Starting the PLC program.

NOTE: RETAIN data are remanent data. They are saved when the Controller is switched off and are available to it when it is rebooted. If these data are deleted, important system data of the application may be deleted!

→ PLC
“RESET WARM”

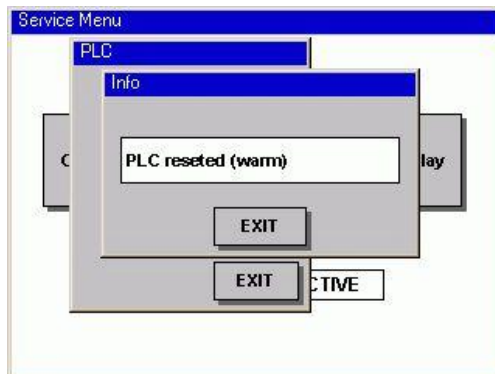

Info:

Acknowledgement of the RESET WARM command. PLC program and all variables, with the exception of the RETAIN variables, have been reset.

→ PLC
“RESET COLD”

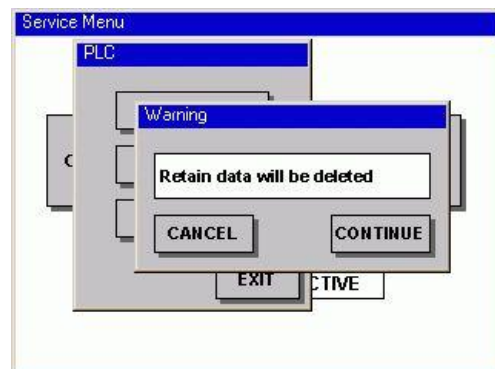

Warning:

Acknowledgement of the RESET COLD command.

As soon as the “CONTINUE” button is pressed the PLC program and all variables, including the RETAIN variables, are reset.

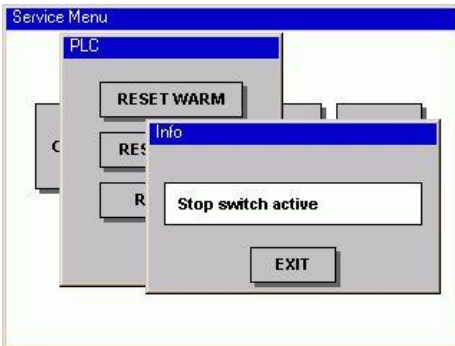

Info:

→ PLC "RUN PLC"

If there is a PLC program on the Dialog-Controller and it was possible to start it successfully, the Service Menu is terminated and PLC program executed. If the PLC program is not executed, the following may be the causes:

- There is no PLC program on the Dialog-Controller.
- Mode selector switch is set at "STOP".
- An error in the PLC program was not acknowledged by a "RESET" command (see above).

"INFO" service menu

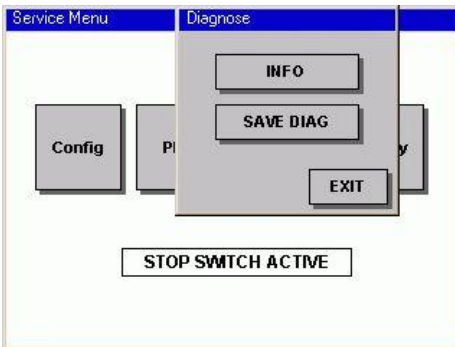

Diagnostics:

→ "Info"

INFO: Diagnostic data displayed

SAVE DIAG: Diagnostic data is saved on USB stick or SD card.

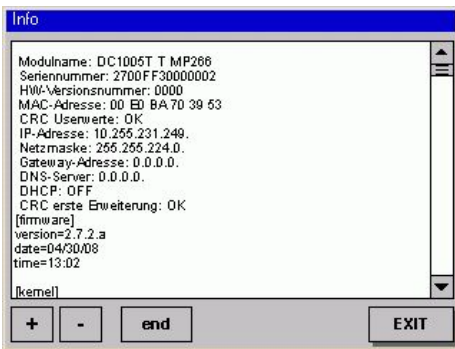

Info:

→ Info

Diagnostic data displayed:

- Parameter display
- Hardware and software versions
- Event logger

Displays all user activities as well as messages and software module problems.

To aid in diagnostics, the entire content of the displayed page can be uploaded to a PC using the integrated "Web Configuration" where it can then be saved and sent to Berghof. The individual event logger messages as well as the web configuration are explained in the "CANtrol PPC System Introduction" manual.

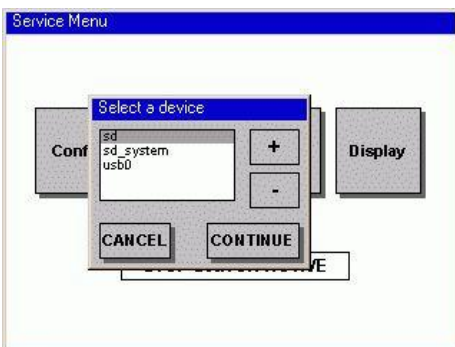

Select a device:

→ Info "SAVE DIAG"

The currently available storage media are displayed here. If neither a USB stick nor an SD card is available, the selection is empty.

sd: Data partition of the SD card

sd_system: System partition of an SD card is used, for example, for the PLC program

usb0: the first USB to be plugged in (a maximum of 8 sticks can be plugged in via a USB hub).

“Display” service menu

→ Display

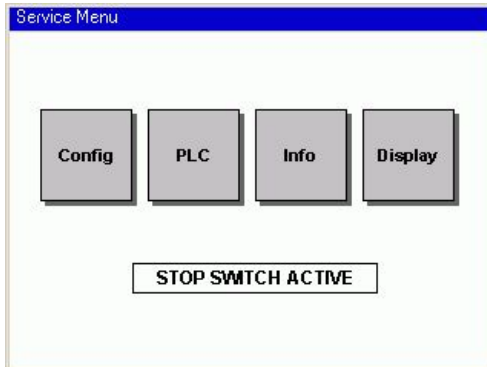

Status display or contrast and backlighting adjustment.

→ Display
“Brightness”

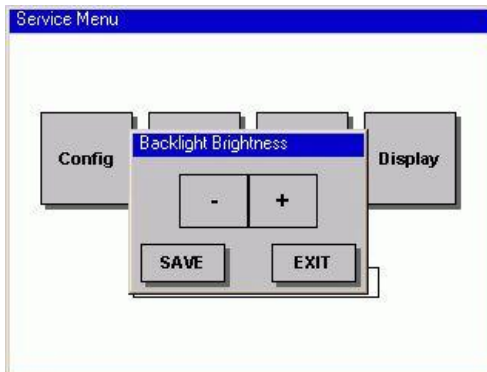

Dialog-Controllers with TFT displays:

The brilliance of the backlighting can be set by means of the “+/-” keys. Changes are applied immediately and will remain in effect until the next restart, even if you leave the menu with the “EXIT” button. The new value is saved by means of the “Save” button. The “EXIT” button allows you to leave the menu without saving any changes which may have been made (although such changes will remain in effect until the next restart).

Dialog-Controllers with monochrome displays:

The contrast can be adjusted here.

3.3.3. PLC window

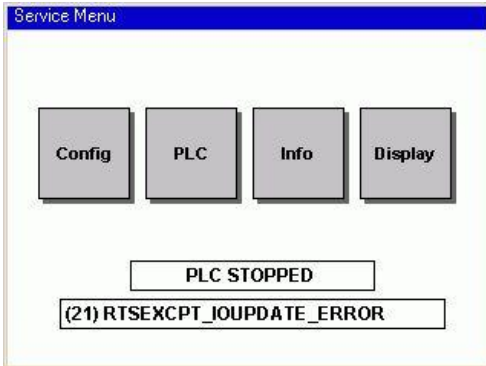

The following states of the PLC Controller can be represented in line 1 of the PLC window:

→ [STOP](#)
in the Service menu

- STOP SWITCH ACTIVE
- PLC STOPPED
- PLC NO PROGRAM
- PLC ERROR STOP

Display	Description
STOP SWITCH ACTIVE	Operating mode selection switch S1 is set to the STOP position. The PLC program can only be started with a programming tool if S1 is set in the RUN position.
PLC STOPPED	Operating mode selection switch S1 is set to the RUN position. However the PLC program has been put into the STOP state or there is another upcoming error, which has not yet been acknowledged with RESET.
PLC NO PROGRAM	Operating mode selection switch S1 is set to the RUN position, but no PLC program is loaded.
PLC ERROR STOP	Operating mode selection switch S1 is set to the RUN position. However, the PLC program could not be started due to an error.

If an error occurs when the PLC program is started, the following states may be displayed on line 2 in the PLC window:

Display	Description
BOOTPROJECT_REJECTED_RETAIN_ERROR	<p>The Dialog-Controller has detected a difference between the PLC program saved as the boot project and the most recently loaded PLC program. The latter was only loaded to RAM and was not saved as a boot project. If the Dialog-Controller is switched off in this situation; the system notes the ID number of the program previously loaded to RAM. The displayed message now prevents the automatic startup of a possibly outdated PLC program.</p> <p>Error correction: Either load, save and then start the new PLC program or use a reset command to start the saved and possibly outdated program.</p>
RETAIN_IDENTITY_MISMATCH	<p>The Dialog-Controller was unable to correctly reestablish the retain variables.</p> <p>Error correction: By performing a reset, the saved PLC program can be started using the reset retain variables.</p>
RTSEXCPT_IOUPDATE_ERROR	<p>One or all of the E-bus modules were not detected after the PLC program started. The E-bus modules also include the I/O expansion cards installed in the Dialog-Controller. All E-bus modules entered in the controller configuration must be present and must be supplied with power at the time the program starts.</p> <p>Error correction: Check the number and type of E-bus modules entered in the controller configuration. Check the contacts and wiring connections on these E-bus modules. Once the number of actually available E-bus modules agrees with the controller configuration setting, the controller can be restarted using a reset command.</p>



This display appears if an error has occurred when the PLC program is executed, i.e. during program run.

The following error statuses can be displayed:

- ACCESS_VIOLATION
- RTSEXCPT_WATCHDOG
- RTSEXCPT_DIVIDEBYZERO

→ **EXCEPTION**
Major exceptional errors

Standard procedure in case of an error:

Saving all relevant data is an important factor for error analysis. The diagnostic information generated by the device should be saved for this reason.

“**Save Diag**” is used to store the relevant diagnostic data for example on a plugged-in USB stick. After such an error the Controller must be rebooted. This takes place after data backup, using the “**Reboot**” button.

Note:

The diagnostic data must definitely be saved **prior to re-booting** because only at this time can all the important data be saved!

Display	Description
ACCESS_VIOLATION	<p>Illegal memory access by the PLC program, e.g. by an invalid pointer.</p> <p>Error correction:</p> <p>The program error can be identified from the diagnostic data and/or the Breakpoint List file (BPL) generated by CODESYS, and eliminated. Further information on debugging with the aid of BPL files and debugging in general is to be found in the "CODESYS Online Help" in the "Berghof Target" section.</p>
RTSEXCPT_WATCHDOG	<p>It was not possible for a task within the PLC program, which is monitored by a watchdog to become active during the monitoring time. This important watchdog-monitoring makes it possible to find errors in the execution behaviour and in the tasking of the PLC program. For such errors to be found at all it is important that each task is monitored by a watchdog.</p> <p>Error correction:</p> <p>The program error can be identified from the diagnostic data and/or the Breakpoint List file (BPL) generated by CODESYS, and eliminated. Further information on debugging with the aid of BPL files and debugging in general is to be found in the "CODESYS Online Help" in the "Berghof Target" section.</p>
RTSEXCPT_DIVIDEBYZERO	<p>Division by zero in the PLC program prompts an error stop.</p> <p>Error correction:</p> <p>The program error can be identified from the diagnostic data and/or the Breakpoint List file (BPL) generated by CODESYS, and eliminated. Further information on debugging with the aid of BPL files and debugging in general is to be found in the "CODESYS Online Help" in the "Berghof Target" section.</p>

3.4. Decommissioning

3.4.1. Disposal

Disassembly

The Dialog-Controller must be disassembled into its component parts for disposal. All metal components can be disposed of as recyclable metal.

Electronic waste

All electronic components such as PCBs, drives, etc. must be set aside and disposed of separately. Disposal is generally regulated by national and local ordinances which must be complied with.

Battery



Batteries contain materials which represent health and environmental hazards.

Batteries may only be disposed of at an authorized waste disposal facility. Make sure the battery is fully discharged before disposing of it. If necessary, place an insulating strip across the contacts to prevent short circuits.

3.5. Maintenance

Cleaning

In order to prevent accidental activation and possible problems, the Dialog-Controller must be switched off when the front panel is cleaned. Use a clean, moistened, lint-free cloth to clean the front of the Dialog-Controller.

Please note the following to avoid damaging the front panel when cleaning it:

- Never use high-pressure or steam washers.
- Never use caustic cleaning agents (even diluted), abrasives or hard objects to clean the panel.
- Do not apply excessive pressure to the front panel when cleaning it.

3.6. Help in case of problems

Please read the section “Basic safety measures”. If the measures described there do not solve the problem, please contact your supplier’s Service Department.

Fault	Possible cause	Recommended action
No function after the Dialog-Controller is started.	No power supply to the Dialog-Controller.	Make sure the power cord is plugged in. Check the pin assignment for reversed polarity. Check (measure) the connecting voltage.
The Dialog-Controller fails to completely boot.	Memory fault.	Return the device for service.
	Corrupted software.	Put the device in the configuration mode and reload the firmware.

Blank page

4. Extension modules

Slot marking for extension modules

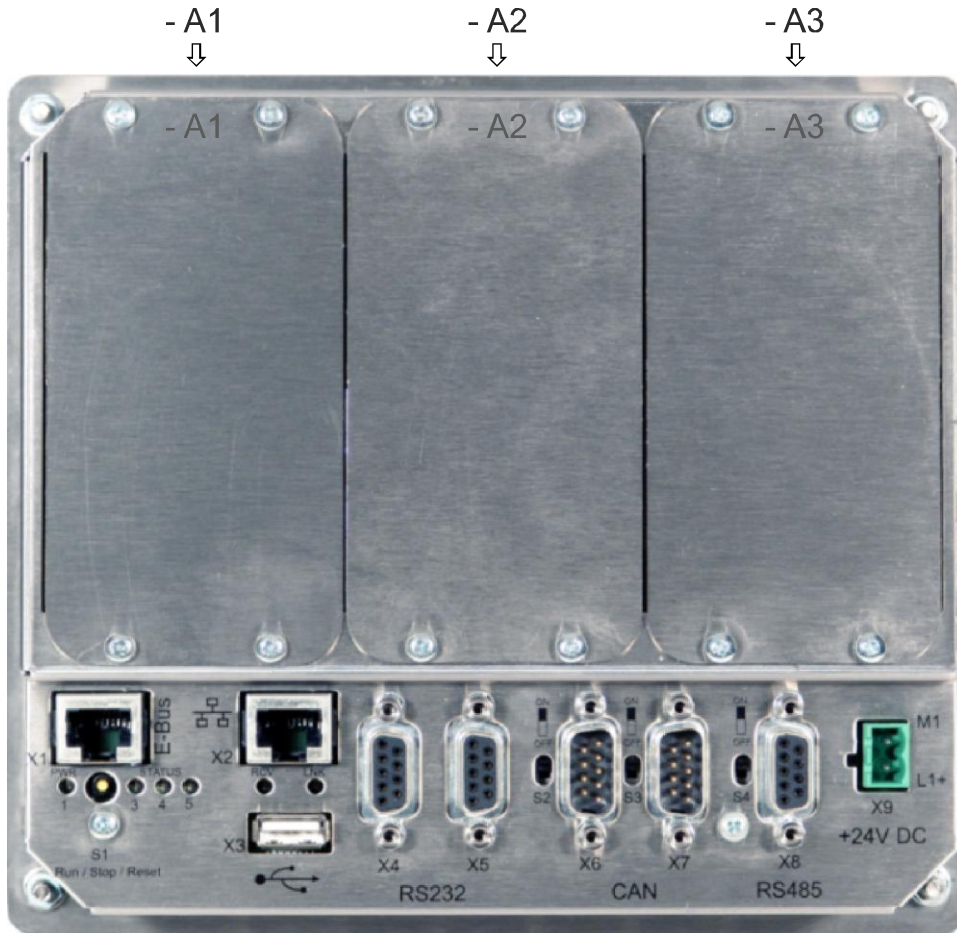

2VF100304DG01.cdr

Extension modules		Slot		
Type	Designation	A1	A2	A3
I/O card with SC-CAN	U DC XS 12/8/4-CSC		X	
PROFIBUS master	DC Profibus-DPM	X		
PROFIBUS slave	DC Profibus-DPS	X		
PROFIBUS master/slave	DC Profibus-DPV	X		
I/O card, analog/digital	DCXR01	X	X	X
I/O card, digital	DCXR02	X	X	X

4.1. I/O card with SC-CAN interface

→ [Short description](#)

The I/O card is an I/O module which is permanently installed in a Dialog-Controller.

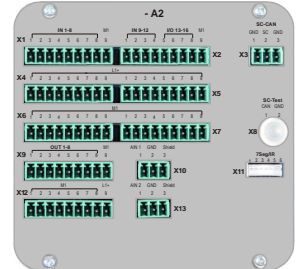

2VF100305DG00.cdr

Performance features - an overview

- 12 digital inputs
- 8 digital outputs
- 4 digital inputs/outputs
- 2 digital inputs can also be used as counters
- 2 analog inputs, 0 ... 10 V or 0 ... 20 mA
- 1 CAN interface for contact line systems with monitoring capability
- Connection for a 5-place 7-segment display with remote control receiver

→ [Scope of supply](#)

The scope of supply of the control module consists of:

- I/O card installed in the Dialog-Controller

4.1.1. Technical data

Module data	
Versions / part no.	Only available as a built-in module
Dimensions, WxH[mm]	113.5 x 108
Weight	Approx. 100 g
Operating temperature range	5 °C to 55 °C (condensation free) Convection cooling ensured
EMI, protection class, insulation test, protection type (installed)	
Interference emission	EN 61000-6-4, industrial application
Interference resistance	EN 61000-6-2, industrial application
Protection class	III
Insulation resistance	EN 61131-2; DC 500 V test voltage
Protection type	IP 20
Supply voltage, current consumption	
Module electronics power supply (connection voltage)	SELV DC +24 V < 0.4 A (EN 61131-2)
Digital I/O power supply	DC +24 V (EN 61131-2) together with module supply
Current consumption	At U _e = DC +24 V in neutral, max. 500 mA, fusing based on I/O load, max. 8 A
Protection against supply voltage pole reversal	Yes
Potential isolation	No
Digitale inputs/outputs (DIO)	
Number of inputs	12 (X1/X2), of which 4 can be used as +24 V encoder inputs; counter frequency at 4x evaluation < 20 kHz
Number of outputs	8 (X9)
Number of inputs/outputs	4 (X2)
Output current	0.5 A
Short circuit protection	Yes
Potential isolation	Yes
Connection technique	Standing front wiring for 3.81 terminal strips (not part of the standard delivery)

Analog inputs	
Number	2 analog inputs, 0 ... 20 mA / 0 ... 10 V switchable (X10/X13)
Input characteristics	Up to 20 mA U < 5 V in case of short circuit, max. 40 mA
Resolution	10 bit (accuracy 8 bit)
Connection technique	Standing front wiring for 3.81 terminal strips (not part of the standard delivery)
CAN interfaces	
Number and type of interfaces	1 CAN interface for (X20) contact line communications / SC_CAN (X3); 1 SC_CAN monitoring interface with standard signals
Connection technique	Standing front wiring for 3.81 terminal strips (not part of the standard delivery)
Operating and display elements	
Display elements	Interface (X11) for 5-place, 7-segment display with IR receiver diode for remote control

4.1.2. Pin assignment

[→ Pin overview](#)

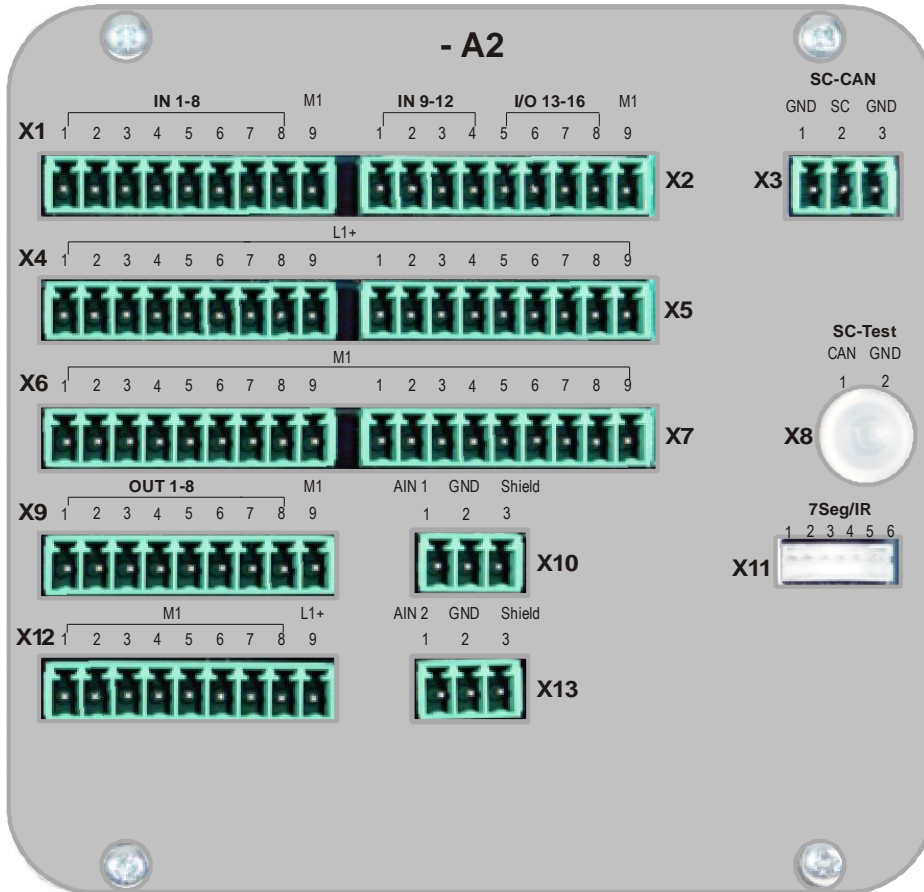

2VF100305DG00.cdr

I/O supply

[→ Power supply](#)

The digital and analog I/Os must be supplied from an external source. An input voltage of 24 VDC (-15 % / +20 %) is permissible. The I/Os are equipped with a built-in pole reversal protection.

The power cord and the external power supply must be equipped with an external short circuit and overload protection with an activation current of max. 8 A (depending on the number of I/Os).

External power supply

The CAN communications interface is supplied from the Dialog-Controller's power supply.

→ Installation

The I/O card is factory installed and may only be installed in the Dialog-Controller in the position shown in the figure below.

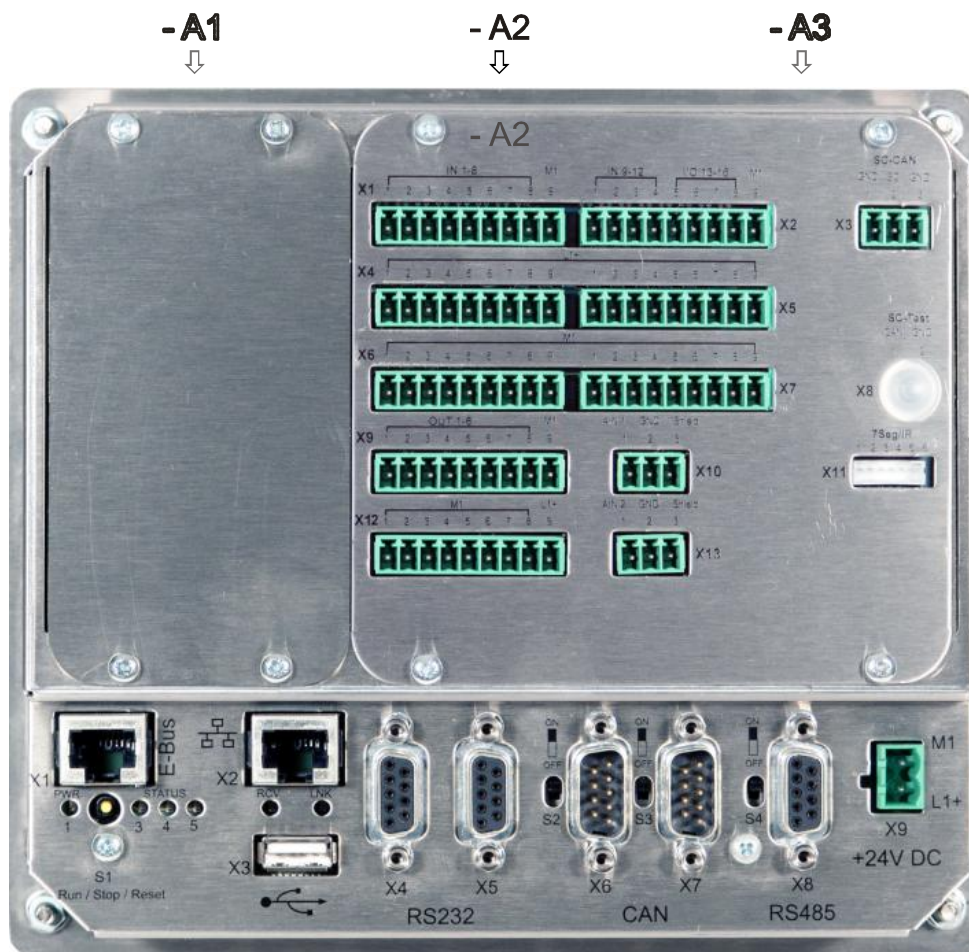

2VF100306DG00.cdr



The transmission circuit voltage level of the SC_CAN signals is 85 V or 110 V at 25 Ohm.

Based on the employed voltage level, all signal carrying lines must exhibit the same level of contact protection as the power supply (230 / 400 V).

→ [CAN bus for contact line communications](#)



Directly connecting ISO11898 devices to the SC_CAN bus will result in there being destroyed and is therefore prohibited.

Such devices include, for example, remote I/Os, drive controllers and CAN bus analyzers.

SC_CAN – X3 pin assignment

Pin	Signal	Description
1	PE	Protective earth
2	SC	SC_CAN signal
3	PE	Protective earth



The two protective earth (PE) connectors must be laid to the contact line connection using two separate conductors.

Any other type of circuit construction (e.g., a bridge between the two PE connections) may result in functional errors or functional inefficiency of the SC_CAN.

Termination

The SC_CAN must be terminated at both line ends. The values for these terminating resistors deviate from the ISO 11898 (CAN bus) standard and they can be ordered separately from Berghof (CTR-SC-T2, part no.: 201601200).



If the SC_CAN bus is incorrectly terminated, its operation can result in the destruction of the I/O subassembly!

You must ensure that the correct termination is employed!

Baud rate

The preset baud rate for the SC_CAN is 50 kbit/s. The SJA1000 CAN controller is also in the “self test mode”, that is, when a CAN telegram is correctly transmitted, it is not necessary for a subscriber to send a CAN ACK signal. Should it become necessary, these factory settings can be altered in the application by using the appropriate CAN library.

→ [2-pin post connector](#) **SC test - X8 pin assignment**

Pin	Signal	Description
1	CAN	CAN signal
2	GND	Signal ground

A test or so-called “monitoring interface” for the SC_CAN is located on this connector. This “monitoring interface” serves to analyze the SC_CAN telegrams and possess the following characteristics:

- It is a point-to-point interface;
- It is only for devices with an ISO11898 CAN interface;
- CAN telegrams cannot be sent;
- No terminating resistors may be employed.

Pin assignment for an adapter cable

2-pin post (2.54)		9-pin Sub D	
Pin	Signal	Signal	Pin
1	CAN	CAN HIGH	2
2	GND	CAN LOW	7

→ [External 7-segment display](#)

For special applications an external 7-segment display (with integrated infrared receiver) can be connected to the I/O subassembly. Connection is to connector X11 by means of a cable available from Berghof. The external display can be addressed from the software in the same way as the digital I/Os.

4.1.3. Analog inputs

The module is equipped with two unipolar analog inputs protected by diodes. Power supply to the sensors is from an external source. The analog current and voltage values are accessible via the CODESYS controller configuration.

Input channel data	
Current measurement	
Nominal input current value	0 ... 20 mA
Maximum input current value	40 mA ($U_e = +24\text{ V}$)
Voltage measurement	
Nominal input voltage value	0 ... 10 V
Maximum input voltage value	12 V
General data	
Input filter, 1 st order	$\tau = 1\text{ ms}$ for current; $\tau = 10\text{ ms}$ for voltage measurement
Conversion method	Successive approximation, no error codes
Resolution	10 bit; 1 LSB = 19.5 μA / 9.77 mV
Accuracy within the 0...50 °C temperature range	$\pm 1\%$
Pole reversal protection	Yes
Sampling rate	Approx. 1 ms



Due to internal protective circuitry, the load is nonlinear for current operation.

Analog IN – X10/13 pin assignment

Pin	Signal	Description
1	AIN	Analog input
2	GND	Signal ground
3	Shield	Shield

The maximum value will be indicated if no sensor is connected to an analog input.



Shield support in switchgear cabinet is urgently recommended for reasons of EMC!

4.1.4. Digital inputs/outputs 12/4/8-0.5

Supply is to terminals L1+ and M1. All inputs and outputs have a common feed and therefore also have a common feed potential.

Feed

The feed must come directly (unswitched) from the feed device. Feed for inputs (sensors) must come directly from the feed device. Do not lay the sensor supply across switched circuits.



Feedback can result in the destruction of the module and/or the sensors!

With the group power supply switched off, the connected sensors may produce feedback via the output transistors. Make sure that the sensors are all supplied from the same power source as the module's associated I/O group.

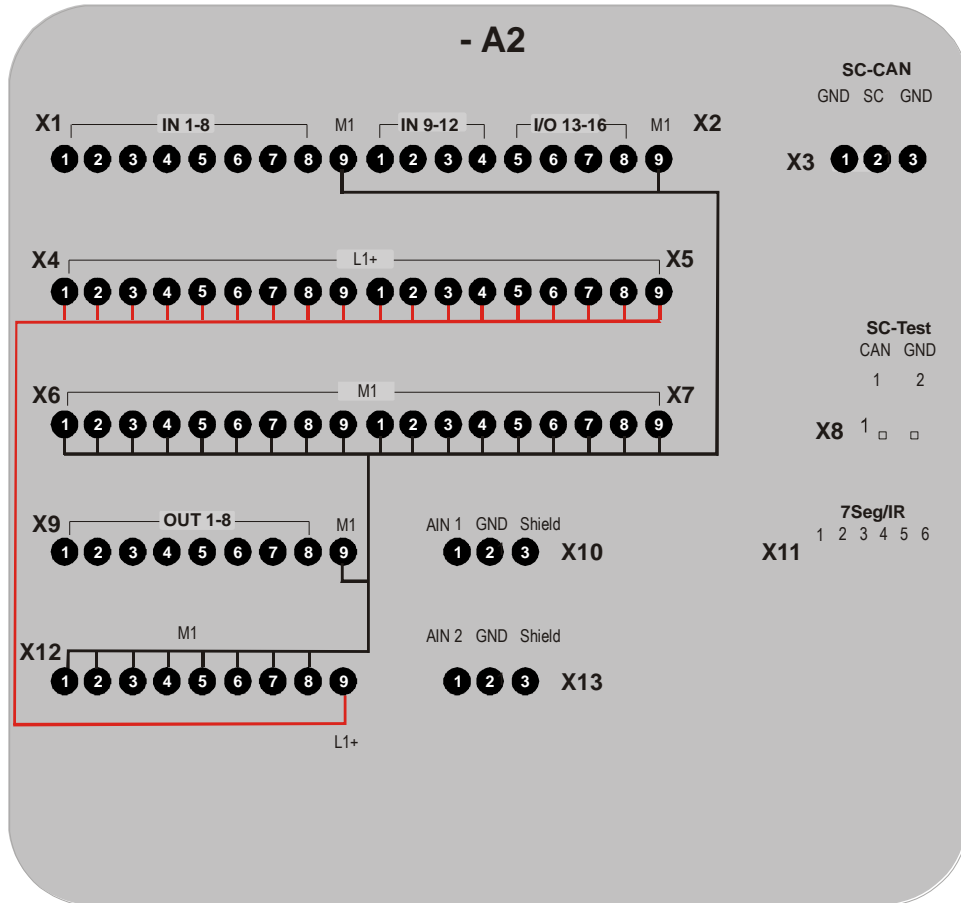

2VF100307DG00.cdr

4.1.5. Digital inputs, positive switched

The digital inputs are positive-switching, type 1 inputs for 3-wire sensors. They are designed for nominal 24 V input voltages. The inputs are transmitted to the CPU in cycles. An open input is interpreted as being static 0 (LOW).

Impulse detection and interference suppression

Inputs are read in cycles. Impulses of $< 100 \mu\text{s}$ are suppressed by the hardware. The shortest possible sampling rate is $250 \mu\text{s}$. In order for impulses to be properly detected they must be longer than the sampling rate defined by the software.

Multiple sampling can be programmed to suppress interference impulses. The sampling rate and multiple sampling (filtering) can be activated in individual groups of 32 inputs.



This function is only available for C applications. The sampling rate is predefined under IEC 61131-3.

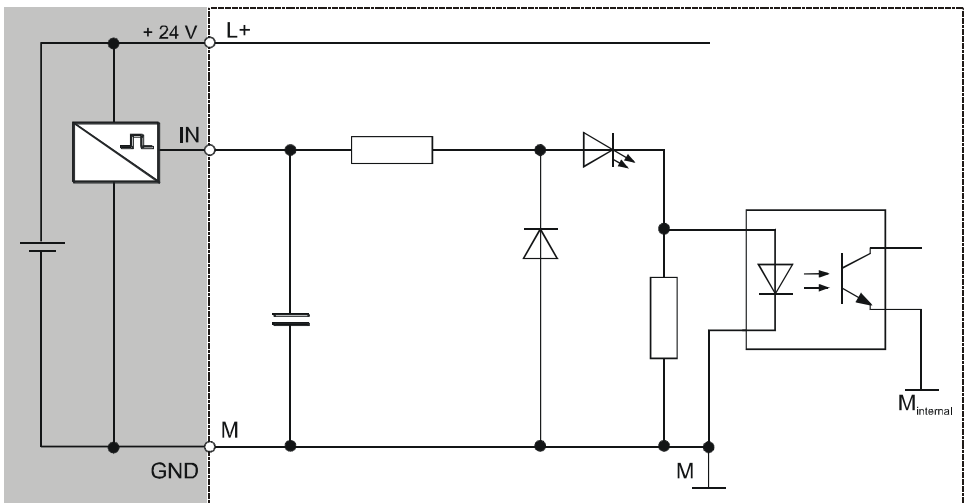

→ [Basic input circuit diagram](#)

2VF100009DG01.cdr

Digital input data		
Module data		
Number of inputs		12 (max. 16 if the I/O is used as an input)
Line length	in the circuit cabinet	Take the voltage drop into account when selecting a conductor. Other than this, there are no relevant restrictions.
	field wiring	Comply with all locally applicable requirements as well as those in accordance with EN 61131-3. Where the risk of lightning exists, please consult the manufacturer.
Nominal load voltage, L+		DC 24 V (SELV)
Pole reversal protection		Yes
Potential isolation		Yes (optocoupler) in groups
Status indicator		None
Alarms		Definable depending on the software
Input delay		Definable via the software
Input capacitance		< 10 nF

→ Operating ranges of the digital inputs

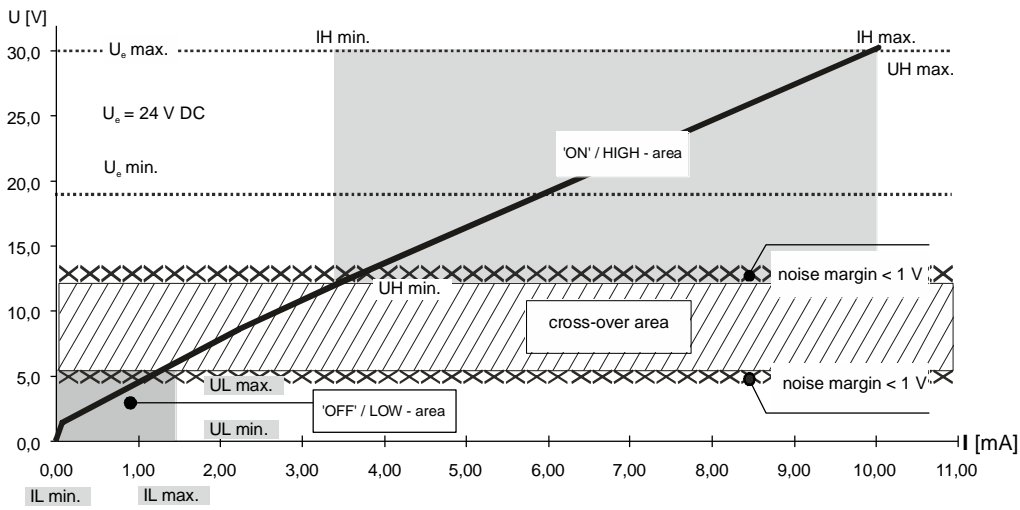

2VF100010DG01.cdr

Input voltage (DC) of extern power supply

U_e	24 V	Rated voltage
$U_e \text{ max.}$	30 V	Upper limit
$U_e \text{ min.}$	19.2 V	Lower limit

Limits for "1" signal for the "ON" condition

$U_{H \text{ max.}}$	30.0 V	Upper voltage limit
$I_{H \text{ max.}}$	10.0 mA	Upper current limit
$U_{H \text{ min.}}$	13.5 V	Lower voltage limit
$I_{H \text{ min.}}$	3.5 mA	Lower current limit

Limits for "0" signal for the "OFF" condition

$U_{L \text{ max.}}$	5.5 V	Upper voltage limit
$I_{L \text{ max.}}$	1.5 mA	Upper current limit
$U_{L \text{ min.}}$	0 V	Lower voltage limit
$I_{L \text{ min.}}$	0 mA	Lower current limit

4.1.6. Digital outputs, positive switched



Voltages of > 32 V and / or feed back can destroy the module.
This represents a fire hazard!

Each digital output can also be used as an input. When used as an input, the information provided under “Digital inputs” applies.

Outputs

The outputs are positively switching 24 V outputs (2-wire). Output current max. 500 mA per output. The outputs have a common reference potential (GND). Power supply is separate from the module electronics supply (refer to “Pin assignment”). If there is no data connection to the CPU or if the internal module supply is inadequate the outputs independently switch to “o” (LOW).

Protected output

All outputs are protected by an internal current limiter and thermal overload protection. In case of an overload, the current limiter switches the overloaded output off. Once the overload has been corrected and the unit has cooled down the output can be reactivated via the program. A quick deactivation using a terminal voltage of 50 V referenced to L+ protects all outputs against induced voltage peaks from inductive loads. If feedback or the quick deactivation produces thermal loads, the overload protection may also be prematurely tripped by uninvolved outputs.

Operating status

The status of each output is indicated by a yellow status LED on the front of the module. The LEDs are spatially assigned to the connection terminals. The LED is on when the associated output is activated, that is, when it is logical “1” (HIGH).

→ Basic output circuit diagram

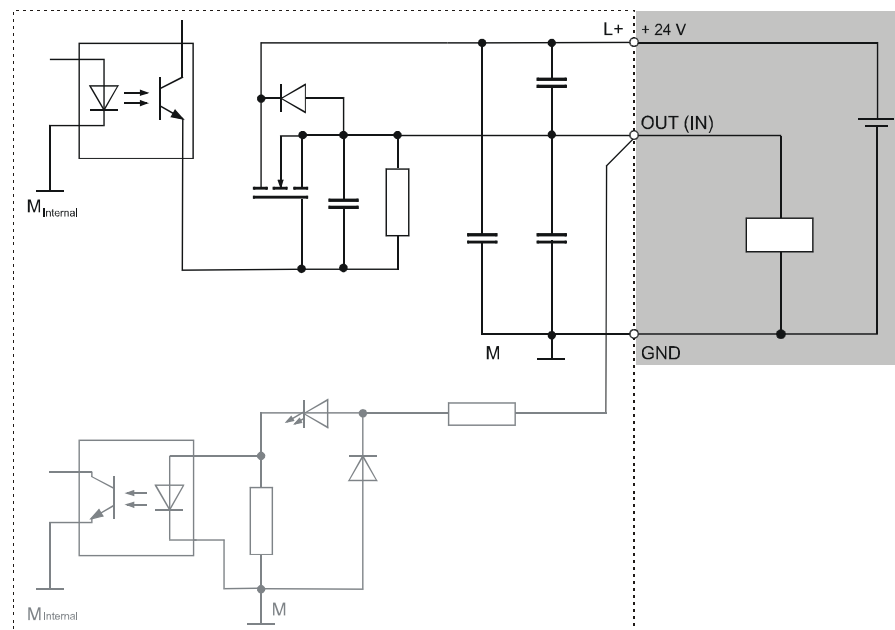

2VF100011DG01.cdr

Digital output data	
Module data	
Number of outputs	8 (max. 12 if the I/O is used as an output)
Type of output	Semiconductor, non-saving
Protected circuit for inductive loads	Quick deactivation, 50 V terminal voltage (typical) against +24 V
Power dissipation resulting from deactivation	Max. 0.5 W / output; max. 4 W / module
Status indicator	None
Diagnostic function	None
Load connection	
Total load (100%)	6 A (12 x 0.5 A)
Overload protection	Yes, for thermal overloads. Activation of the thermal overload protection may influence adjacent outputs.
Short circuit protection ¹⁾ Activation threshold	Yes, electronic current limiter min. 0.5 A; typically 0.9 A.
¹⁾ Current is electronically limited. Activation of the short circuit protection results in a thermal overload which activates the thermal overload protection.	
Output delay from "0" to "1" from "1" to "0"	Max. 0.5 ms Max. 0.5 ms
Output capacitance	< 20 nF
Reference voltage Voltage drop (at reference current)	DC +24 V < 0.5 V
Reference current for "1" signal Leakage current for "0" signal	0.5 A Max. 0.1 mA
Total current, all outputs (horizontal installation on vertical panel)	Max. 6 A (12 x 0.5)
Lamp load (DC +24 V)	Max. 6 W
Parallel switching of two outputs for logical linkage to increase performance	Permissible Prohibited
Insulation resistance	
Reference voltage	$0\text{ V} < U_e < 50\text{ V}$
Test voltage up to an altitude of 2000 m	DC 500 V

Overload behavior of the digital outputs

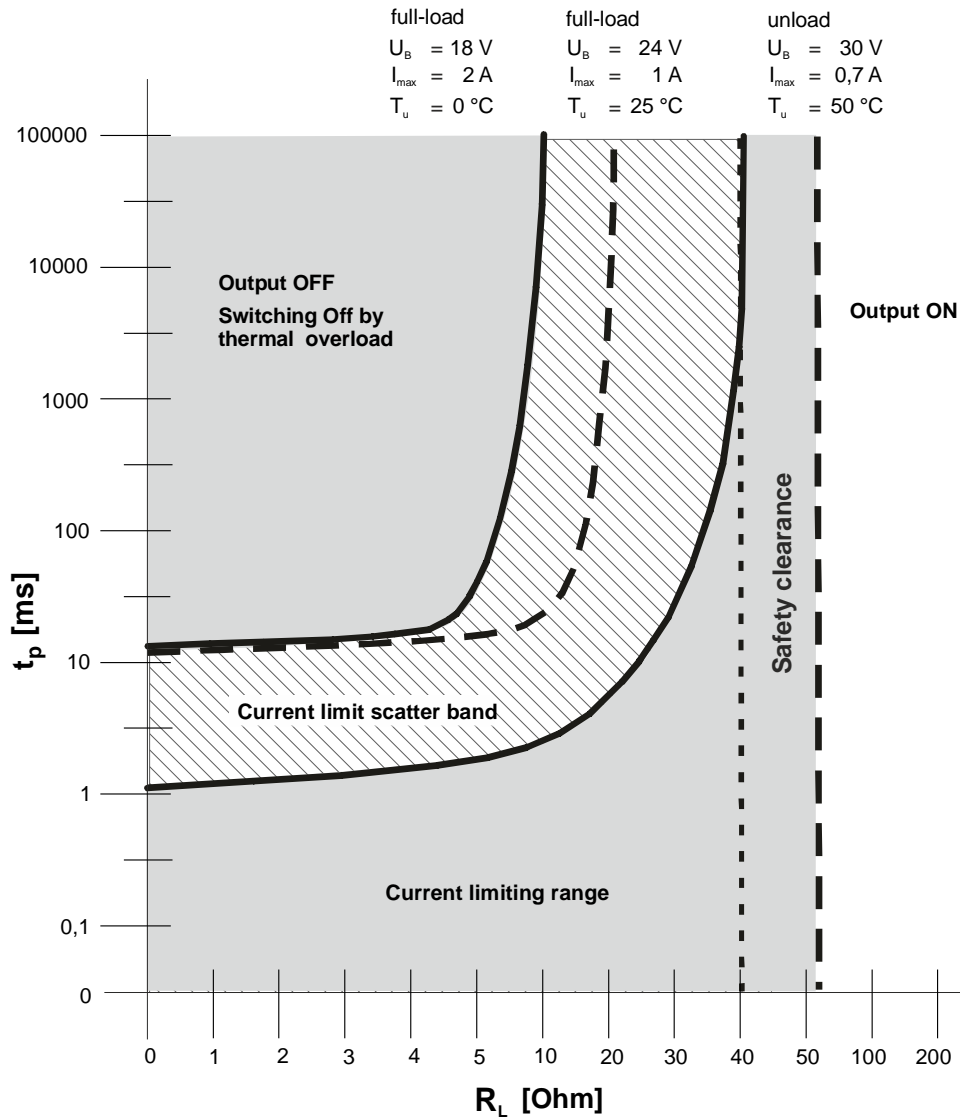

Within the current-limiter scatter band the reaction of current limiting is undefined.

2VF100021DG01.cdr

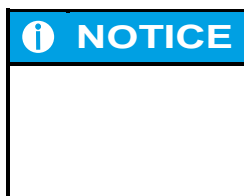

No assurance as to whether a shutdown or a return to the working range will occur can be made within the current limiter scatter band. Therefore, this state should be avoided!

The output will again be operational once the overload has been corrected and the unit has cooled down.

4.1.7. Digital input/output pin assignments

Connection		Signal name	Configured as Digital I/O	TPU-I/O	Note
X12	9	L1+	Feed		
X12	1 ... 8	M1	GND for module and I/O feed		
X9	9				
X7	1 ... 9				
X6	1 ... 9				
X1	9				
X2	9				
X4	1 ... 9			+24 V =	I/O feed
X5	1 ... 9				
X1	1	IN1	Digital IN +24 V	Counter input, +24 V	Form encoder 1
	2	IN2	Digital IN +24 V	Counter input, +24 V	
	3	IN3	Digital IN +24 V	Counter input, +24 V	Form encoder 2
	4	IN4	Digital IN +24 V	Counter input, +24 V	
	5	IN5	Digital IN +24 V		
	6	IN6	Digital IN +24 V		
	7	IN7	Digital IN +24 V		
	8	IN8	Digital IN +24 V		
X2	1	IN9	Digital IN +24 V		
	2	IN10	Digital IN +24 V		
	3	IN11	Digital IN +24 V		
	4	IN12	Digital IN +24 V		
	5	I/O13	Digital I/O +24 V		
	6	I/O14	Digital I/O +24 V		
	7	I/O15	Digital I/O +24 V		
	8	I/O16	Digital I/O +24 V		
X9	1	OUT1	Digital OUT +24 V		
	2	OUT2	Digital OUT +24 V		
	3	OUT3	Digital OUT +24 V		
	4	OUT4	Digital OUT +24 V		
	5	OUT5	Digital OUT +24 V		
	6	OUT6	Digital OUT +24 V		
	7	OUT7	Digital OUT +24 V		
	8	OUT8	Digital OUT +24 V		

→ [Encoder interface](#) Groups of 2 inputs can be combined to form a quadrature encoder for evaluation.

Function	Input 1	Input 2
Encoder 1	IN 1 (X1)	IN 2 (X1)
Encoder 2	IN 3 (X1)	IN 4 (X1)

The encoder values are only reset (0) when the unit is switched on or rebooted after a reset.

4.2. PROFIBUS-MASTER card

The PROFIBUS-MASTER card is a PROFIBUS-MASTER module, permanently installed in a Dialog-Controller.

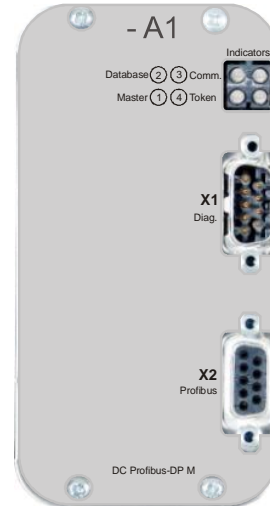

[→ Short description](#)

2VF100308DG00.cdr

Performance features – an overview

- PROFIBUS-DP Master bus module
- Max. of 125 slave nodes can be connected
- Max. 3 kbyte process data (1536 byte input and 1536 byte output data)
- Baud rates 9600 bit/s - 12 Mbit/s
- Potential isolated PROFIBUS-MASTER RS485 interface with integrated DC/DC converter and opto-couplers
- Cyclic DP-Master services

The scope of supply consists of:

- PROFIBUS-MASTER card installed in the Dialog-Controller

[→ Scope of supply](#)

4.2.1. Technical data

Module data	
Versions / part no.	Only available as a built-in module
Dimensions, WxHxD [mm]	56.5x108x8
Weight	Approx. 100 g
Operating temperature range	5 °C to 55 °C (condensation free) Convection cooling ensured
EMI, protection class, insulation test, protection type (installed)	
Certification	CE, UL, cUL
Interference emission	EN 61000-6-4, industrial application
Interference resistance	EN 61000-6-2, industrial application
Protection class	III
Insulation resistance	EN 61131-2; DC 500 V test voltage
Protection type	IP 20
Supply voltage, current consumption	
Module electronics power supply (connection voltage)	5 V / max. 350 mA from the Dialog-Controller's mains power supply
PROFIBUS-MASTER interfaces	
Number and type of interfaces	1 PROFIBUS-MASTER DP interface for connecting a max. of 125 slave nodes
Potential isolation	Yes
Connection technique	9-pin, Sub-D
Operating and display elements	
Display elements	4 diagnostic LEDs

4.2.2. Front view and pin assignment

[→ Pin overview](#)

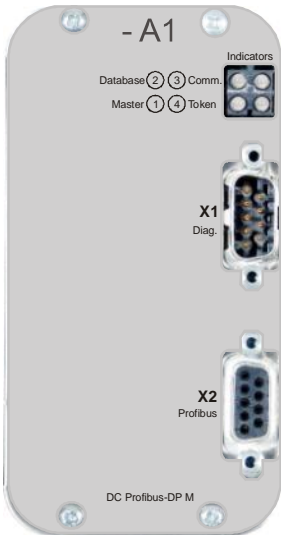

2VF100308DG00.cdr

External power supply

The PROFIBUS-MASTER communications interface is supplied from the Dialog-Controller's power supply.

Installation

The PROFIBUS-MASTER card is factory installed and may only be installed in the Dialog-Controller in the position shown in the figure below.

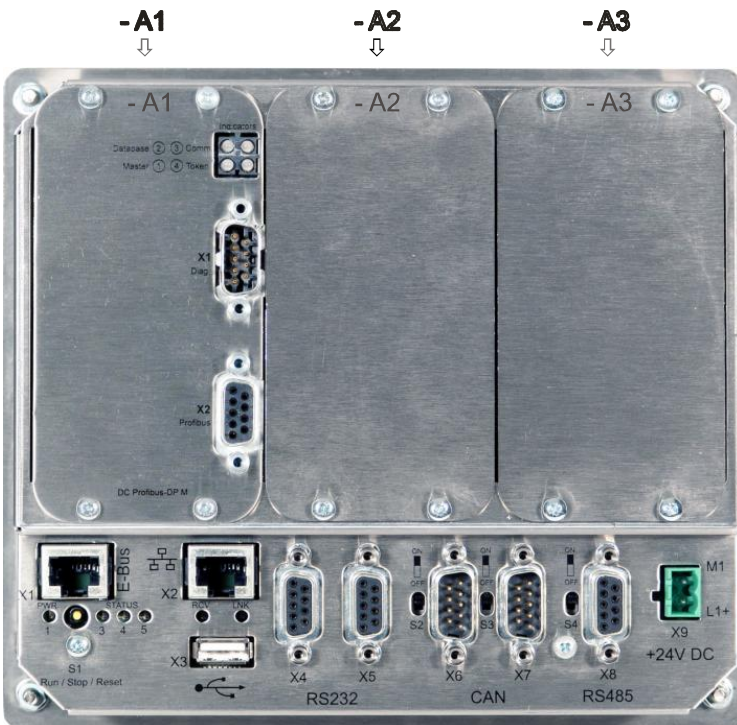

2VF100309DG00.cdr

→ PROFIBUS-MASTER interface

The embedded PROFIBUS-MASTER bus module is a PROFIBUS DP Master. The module has been tested for conformity with the PROFIBUS standard and for inter-operability with many leading PROFIBUS slave devices. The onboard microprocessor automatically performs all PROFIBUS bus traffic thus completely relieving the automation device's main processor of any PROFIBUS protocol processing.

The PROFIBUS-MASTER module supports a max. of 125 slaves with up to 3 kbyte of I/O data. All baud rates from 9.6 kbit/s to 12 Mbit/s can be set. All cyclic PROFIBUS services are available.

→ galvanically isolated field bus interface

PROFIBUS-X2 (jack) pin assignment

Pin	Signal	Description
1	N.C.	Do not connect
2	N.C.	Do not connect
3	B	RS485 signal
4	RTS	Ready to send
5	GND	Bus ground
6	+5 V	Bus (output)
7	N.C.	Do not connect
8	A	RS485 signal
9	N.C.	Do not connect

→ serial diagnostics interface

Diag.-X1 (pins) pin assignment

Pin	Signal	Description
1	N.C.	Do not connect
2	RxD	RS232 signal
3	TxD	RS232 signal
4	N.C.	Do not connect
5	GND	Bus ground
6	N.C.	Do not connect
7	N.C.	Do not connect
8	N.C.	Do not connect
9	N.C.	Do not connect



All application and diagnostic data are set up via the CODESYS controller configuration or are provided by the application. Therefore, the diagnostic interface cannot be used in an application-specific manner.

Termination

The PROFIBUS-MASTER has a linear topology. It must be terminated at both ends. The PROFIBUS-MASTER module is not equipped with any internal terminating resistors and we therefore recommend the use of a plug with switchable termination.

Baud rate

The baud rate is set in the CODESYS controller configuration.

GSD file

The PROFIBUS-MASTER module is integrated in the CODESYS controller configuration with a GSD file. As of Version 1.10.0, this GSD file will be part of the Berghof Target installation package.

Indicator LEDs

Indica- tor	Signal	Description	
1	Master	Green:	Operating mode
		Green, flashing:	Delete mode
		Red:	Stop mode
		Off:	Offline
2	Database	Green:	Databank OK
		Green, flashing:	Database load procedure running
		Red:	Database invalid
		Off:	No database available
3	Comm.	Green:	Data exchange with all configured slaves
		Green, flashing:	Data exchange with at least 1 configured slave
		Red:	Bus error, e.g., due to a short circuit or configuration error
		Off:	No data exchange
4	Token	Green:	Module has the token
		Off:	Token not at the module
All		Red:	Fatal error

4.3. PROFIBUS-SLAVE card

→ Short description

The PROFIBUS-SLAVE card is a PROFIBUS-SLAVE module, permanently installed in a Dialog-Controller.

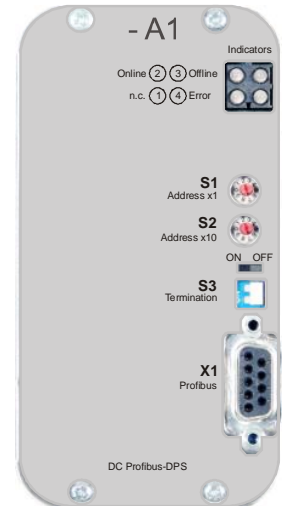

2VF100310DG00.cdr

Performance features – an overview

- PROFIBUS-DP SLAVE bus module
- Max. 244 byte input and 244 byte output data (all together 416 byte)
- Automatic baud rate recognition, 9600 bit/s - 12 Mbit/s
- Potential isolated PROFIBUS-SLAVE RS485 interface with integrated DC/DC converter and optocouplers
- All required DP services as well as user parameter data and device-specific diagnostics

→ Scope of supply

The scope of supply consists of:

- PROFIBUS-SLAVE card installed in the Dialog-Controller

4.3.1. Technical data

Module data	
Versions / part no.	Only available as a built-in module
Dimensions, WxHxD [mm]	56.5x108x8
Weight	Approx. 100 g
Operating temperature range	5 °C to 55 °C (condensation free) Convection cooling ensured
EMI, protection class, insulation test, protection type (installed)	
Certification	CE, UL, cUL
Interference emission	EN 61000-6-4, industrial application
Interference resistance	EN 61000-6-2, industrial application
Protection class	III
Insulation resistance	EN 61131-2; DC 500 V test voltage
Protection type	IP 20
Supply voltage, current consumption	
Module electronics power (connection voltage)	5 V / max. 350 mA from the Dialog-Controller's mains power supply
PROFIBUS-SLAVE interfaces	
Number and type of interfaces	1 PROFIBUS-SLAVE interface DP
Potential isolation	Yes
Connection technique	9-pin, Sub-D
Operating and display elements	
Display elements	4 diagnostic LEDs
Address switch	Switches not used for applications
Termination	Switchable terminating resistor

4.3.2. Front view and pin assignment

→ [Pin overview](#)

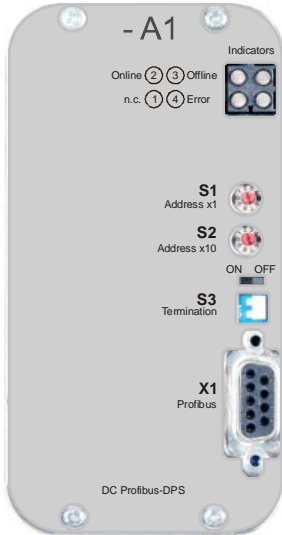

2VF100310DG00.cdr

External power supply

The PROFIBUS-SLAVE communications interface is supplied from the Dialog-Controller's power supply.

Installation

The PROFIBUS-SLAVE card is factory installed and may only be installed in the Dialog-Controller in the position shown in the figure below.

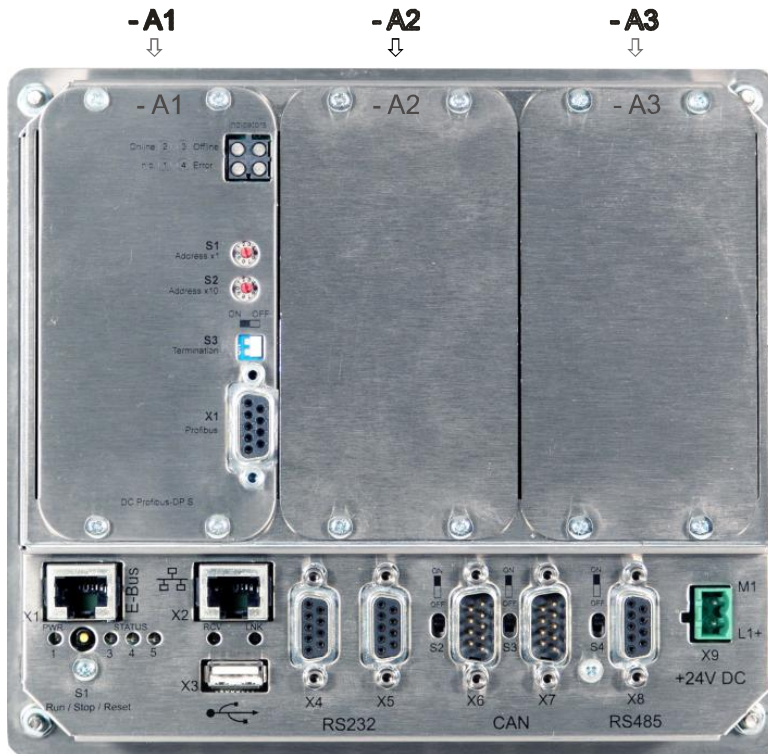

2VF100311DG00.cdr

The embedded PROFIBUS-SLAVE module is a complete PROFIBUS-DP SLAVE. It contains all analog and digital components for a high performance PROFIBUS extension circuit. The module is certified and has been tested for inter-operability with many leading PROFIBUS master subassemblies. The onboard micro-processor automatically performs all PROFIBUS bus traffic thus completely relieving the automation device's main processor of any PROFIBUS protocol processing.

→ [PROFIBUS-SLAVE interface](#)

The PROFIBUS module supports a maximum PROFIBUS data width of 244 input bytes and 244 output bytes as well as all rates from 9.6 kbit/s to 12 Mbit/s.



The PROFIBUS station address is set with the CODESYS controller configuration. Rotary switches S1 and S2 have no effect and can therefore not be used in an application-specific manner.

PROFIBUS-X1 (jack) pin assignment

→ [galvanically isolated field bus interface](#)

Pin	Signal	Description
1	N.C.	Do not connect
2	N.C.	Do not connect
3	B	RS485 signal
4	RTS	Ready to send
5	GND	Bus ground
6	+5 V	Bus (output)
7	N.C.	Do not connect
8	A	RS485 signal
9	N.C.	Do not connect

Termination, S3

The PROFIBUS has a linear topology. It must be terminated at both ends. The PROFIBUS-SLAVE module has an integrated bus termination which can be activated by a DIP switch (ON position).

Baud rate

The baud rate is automatically detected.

GSD file

The PROFIBUS-SLAVE module is integrated in the CODESYS controller configuration with a GSD file. As of Version 1.10.0, this GSD file will be part of the Berghof Target installation package.

Indicator LEDs

Four diagnostic LEDs indicate the current operating state and any error messages.

Indicator	Signal	Description	
1	N.C.	Not used	
2	Online	Green:	Online / data exchange permitted
		Off:	Not online
3	Offline	Red:	Offline, no data exchange possible
		Off:	Not offline
4	Error	Red, flashing at 1 Hz:	Configuration error; initialized data length does not match configuration
		Red, flashing at 2 Hz:	Missing user parameter; initialized data length does not match configuration
		Red, flashing at 4 Hz:	Initialization error in the ASIC
		Off:	No diagnostic data available

4.4. PROFIBUS card (Master/Slave functionality)

The PROFIBUS card is a PROFIBUS module, with Master and/or Slave functionality, permanently installed in a Dialog-Controller.

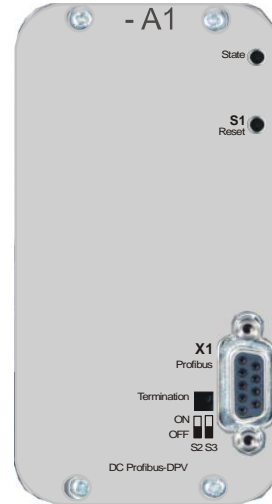

[→ Short description](#)

2VF100404DG00.cdr

Performance features – an overview

- PROFIBUS-DP master and slave bus module
- Max. of 125 slave nodes can be connected
- Max. total process data 1 kbyte (512 bytes input and 512 bytes output data)
- PROFIBUS Slave (max. 200 bytes input and 200 bytes output data)
- Baud rates 9600 bit/s - 12 Mbit/s
- Potential isolated PROFIBUS RS485 interface with integrated DC/DC converter and optocouplers
- Cyclic DP master services

The scope of supply consists of:

- PROFIBUS card installed in the Dialog-Controller

[→ Scope of supply](#)

4.4.1. Technical data

Module data	
Versions / part no.	Only available as a built-in module
Dimensions, WxHxD [mm]	56.5x108x8
Weight	Approx. 100 g
Operating temperature range	5 °C to 55 °C (condensation free) Convection cooling ensured
EMI, protection class, insulation test, protection type (installed)	
Certification	CE
Interference emission	EN 61000-6-4, industrial application
Interference resistance	EN 61000-6-2, industrial application
Protection class	III
Insulation resistance	EN 61131-2; DC 500 V test voltage
Protection type	IP 20
Supply voltage, current consumption	
Module electronics power supply (connection voltage)	5 V / max. 370 mA from the Dialog-Controller's mains power supply
PROFIBUS interfaces	
Number and type of interfaces	1 PROFIBUS DP Master interface and 1 PROFIBUS DP Slave interface for connecting 125 Slave nodes max.
Potential isolation	Yes
Connection technique	9-pin, Sub-D
Operating and display elements	
Termination	Via dip switch or configuration file

4.4.2. Front view and pin assignment

Termination switches S2 and S3:

The terminating resistors are part of the bus physics and prevent reflections. They have nothing to do with Master and Slave. A terminating resistor must be in place at both ends of the Profibus.

With switches S2 and S3 the terminating resistor required for the Profibus can be connected. It is important for both switches to be in the same position!



External power supply

The PROFIBUS communication interface is supplied from the Dialog-Controller's power supply.

Installation

The PROFIBUS card is factory installed and may only be installed in the Dialog-Controller in the position shown in the figure below.

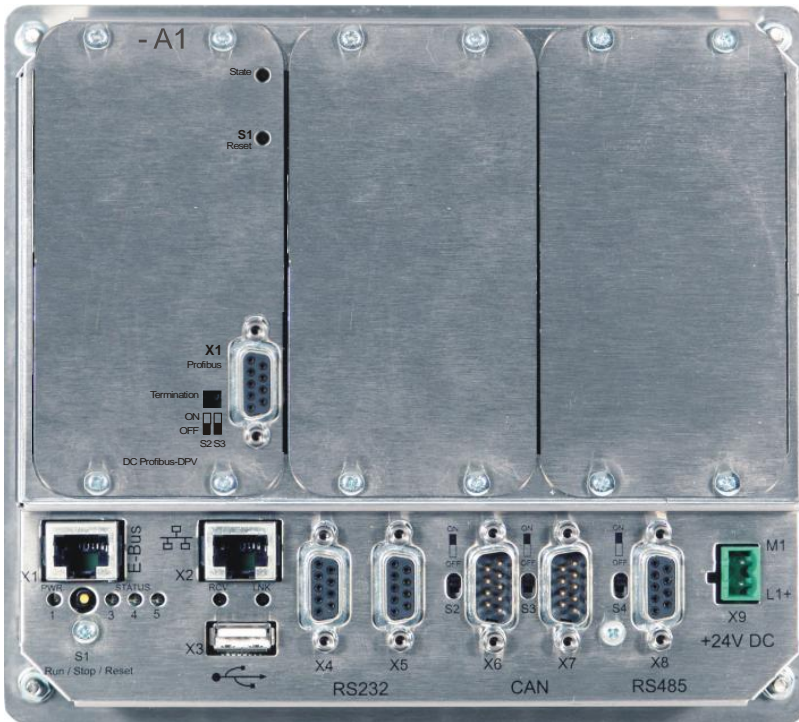

→ PROFIBUS interface

The embedded PROFIBUS bus module has been tested for conformity with the PROFIBUS standard and for inter-operability with many leading PROFIBUS slave devices. The onboard microprocessor automatically performs all PROFIBUS bus traffic thus completely relieving the automation device’s main processor of any PROFIBUS protocol processing.

The PROFIBUS module supports a max. of 125 slaves with up to 1 kbyte of I/O data. All baud rates from 9.6 kbit/s to 12 Mbit/s can be set. All cyclic PROFIBUS services are available.

→ galvanically isolated field bus interface

PROFIBUS-X1 (jack) pin assignment

Pin	Signal	Description
1	N.C.	Do not connect
2	N.C.	Do not connect
3	B	RS485 signal
4	RTS	Ready to send
5	GND	Bus ground
6	+5 V	Bus (output)
7	N.C.	Do not connect
8	A	RS485 signal
9	N.C.	Do not connect

GSD files

The PROFIBUS card has 3 GSD files for configuring the PROFIBUS interface:

- **DPMaster.gsd:** Configuration of PROFIBUS Master
- **DPSlaveInternal.gsd:** With this the PROFIBUS Master can be additionally equipped with a Slave function.
- **DPSlave.gsd:** GSD file for the PROFIBUS Master which can access the card configured as a PROFIBUS Slave



All application and diagnostic data are set up via the CODESYS controller configuration or are provided by the application.

A DUO LED signalizes the current state of the bus and any possible error messages.

→ [State LED](#)

PROFIBUS card configured as Master

Indicator	Signal	Description	
1	State	Orange	No Profibus configuration available
		Green	All configured Slaves are correct on the bus.
		Green 1x flashing	Not all, but at least one, DP Slave is on the bus.
		Green 2x flashing	There is no configured DP Slave on the bus.
		Green 8x flashing	It was not possible to initialize the Profibus Master (incompatibility between Master and configuration files).

PROFIBUS card configured as a Slave

Indicator	Signal	Description	
1	State	Orange	No Profibus configuration available
		Green	The DP Slave is correctly configured on the bus.
		Green 5x flashing	DP Slave not yet correctly addressed by DP Master
		Green 4x flashing	Watchdog error If the watchdog is active the connection to the Master has been lost.

4.5. I/O XR01 and XR02 cards with analog and digital I/O

→ [Brief description](#)

The XR01 I/O card is an extension card with an analog and digital I/O module permanently installed in a Dialog-Controller. The XR02 I/O card possesses only digital I/O.



2VF100466DG00.cdr

Performance features – an overview

DCXR01

- 8 digital inputs
- 8 digital inputs/outputs
- The digital inputs (X2) can also be used as counters.
- 4 analog ± 10 V inputs
- 4 ± 10 V or ± 20 mA analog inputs/outputs

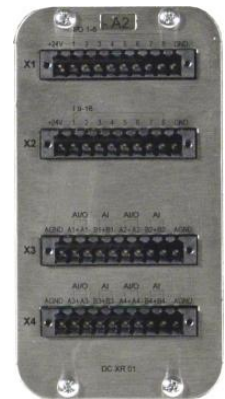

2VF100467DG00.cdr

DCXR02

- 8 digital inputs
- 8 digital inputs/outputs
- The digital inputs (X2) can also be used as counters.



2VF100468DG00.cdr

→ [Scope of supply](#)

The scope of supply of the controller module consists of:

- max. 3 XR I/O cards installed in the Dialog-Controller

4.5.1. Technical data

Module data	
Versions / part no.	Only available as a built-in module
Dimensions, WxH[mm]	56.6 x 108
Weight	Approx. 100 g
Operating temperature range	5 °C to 55 °C (condensation free) Convection cooling ensured and slot A3 not used
EMI, protection class, insulation test, protection type (installed)	
Interference emission	EN 61000-6-4, industrial application
Interference resistance	EN 61000-6-2, industrial application (connector cable < 30 m)
Protection class	III
Insulation resistance	EN 61131-2; DC 500 V test voltage
Protection type	IP 20
Supply voltage, current consumption	
Module electronics power supply (connection voltage)	SELV DC +24 V (-15 % / +20 %) < 0.4 A (EN 61131-2) alternating voltage component max. 5 %
I/O power supply	DC +24 V (EN 61131-2) together with module supply
Current consumption	At $U_e =$ DC +24 V in neutral, max. 500 mA, fusing based on I/O load, max. 12 A
Protection against supply voltage pole reversal	Yes
Potential isolation	No
Digitale inputs/outputs (DIO)	
Number of inputs	8 (X2), up to 8 of which can be used as +24 V encoder inputs; counter frequency at 4x evaluation < 40 kHz
Number of inputs/outputs	8 (X1)
Output current	0.5 A
Short circuit protection	Yes
Potential isolation	No
Connection technique	Standing front wiring for terminal strips (not part of the scope of supply)
Analog inputs/outputs	
Inputs	4 analog ± 10 V inputs
Inputs/Outputs	4 analog ± 10 V or ± 20 mA inputs/outputs
Resolution	Min. 16 bit
Connection technique	Standing front wiring for terminal strips (not part of the scope of supply)

4.5.2. Pin assignment

→ Terminal assignment

DCXR01

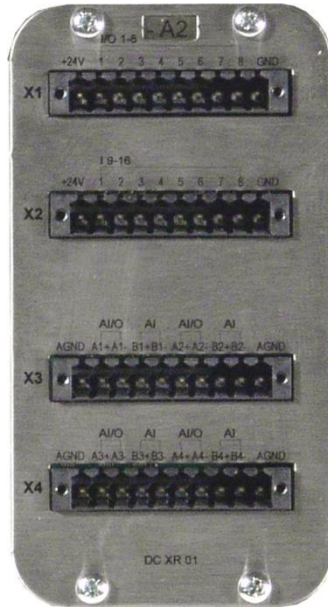

2VF100467DG00.cdr

DCXR02

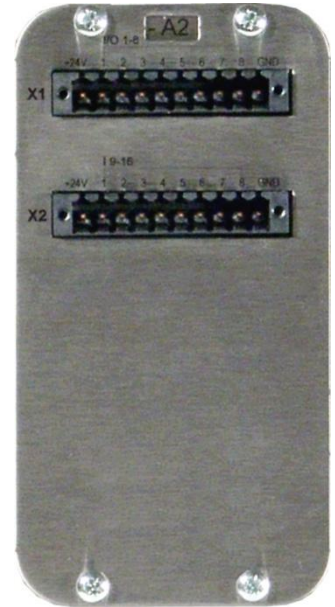

2VF100468DG00.cdr

4.5.3. Power supply

→ I/O supply

The digital and analog I/O must be supplied with power externally. 24 VDC input voltage (-15 % / +20 %) is permissible. The I/O possess integrated polarity reversal protection.

They are supplied with power via X1 or X2. It is not permissible to daisy-chain the power supply. The supply line and the power supply must both be protected by an external short circuit and overload protection with a maximal tripping current of 12 A in each case (depending on the number of I/O).

All digital and analog I/O have a joint supply and operate at the same potential. It is not possible to switch individual I/O areas on and off selectively.

 CAUTION	<p>The I/O cards possess error identification by means of "IO_VALID" software flag.</p> <p>For example, if communication errors, supply errors or errors on the analog outputs occur, this is indicated by "IO_VALID"; at the same time I/O data may not continue to be used.</p> <p>"IO_VALID" does not become valid again until the controller has been restarted. Therefore, it is necessary to constantly monitor "IO_VALID" in the PLC program.</p>
--	---

4.5.4. Plug-in connectors



Using the plug-in connectors with LED destroys analog I/O!

Connections

Plug-in connectors are available with built-in 1- and 3-pin LED. There are no LED displays on the XR I/O cards; therefore plug-in connectors **with** built-in LED must be used for the digital I/O. The analog I/O may only be connected with plug-in connectors **without** LED.

Part no.	Image of plug-in connector	Designation	Description
15417		BL-I/O 3.5/30F PNP LED SW	→ I/O status display with green LED → Three-wire connection → For digital channels only (X1 and X2)
15419		BL-I/O 3.5/10F PNP LED SW	→ I/O status display with green LED → Single-wire connection → For digital channels only (X1 and X2)

→ Plug-in connectors with LED for digital I/O

Part no.	Image of plug-in connector	Designation	Description
15418		BL-I/O 3.5/30F SW	→ Without LED for analog channels (X3 and X4) → Three-wire connection → Makes it easier to connect the shield or GND line
15420		BL-I/O 3.5/10F SW	→ Without LED for analog channels (X3 and X4) → Single-wire connection

→ Plug-in connectors without LED for digital I/O

4.5.5. Installation

The I/O card is installed ex-works and can be installed in the Dialog-Controller at positions A1 / A2 / A3. Up to 3 of the XR I/O cards can be installed in the Dialog-Controller.

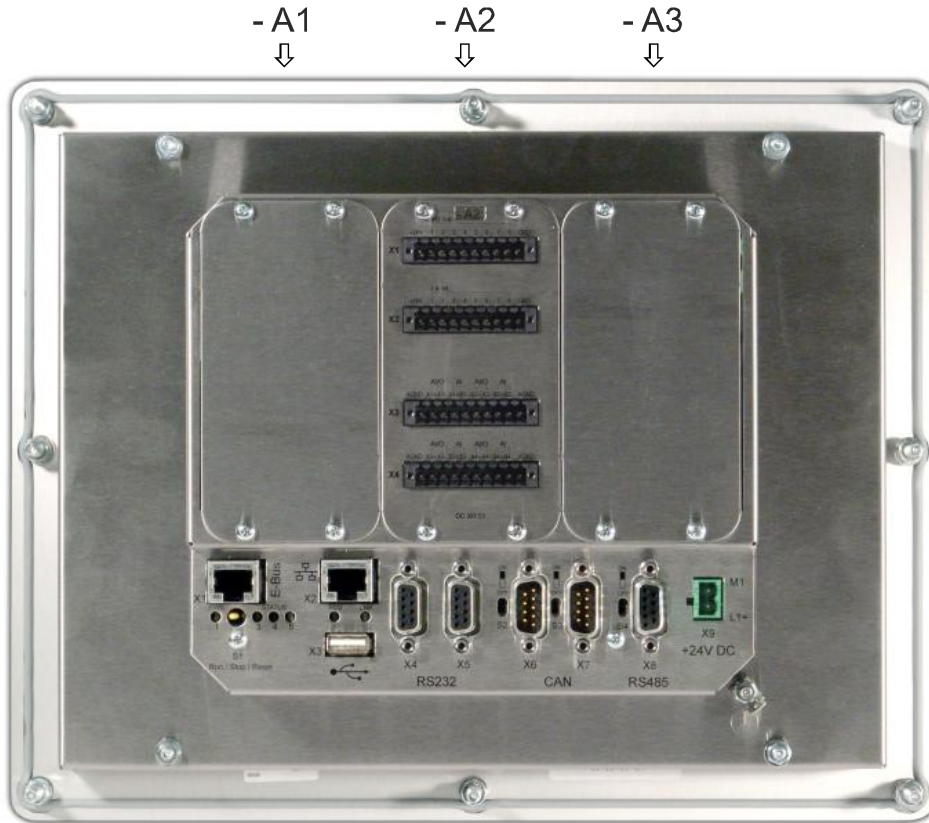

2VF100466DG00.cdr

4.5.6. 8/8-0.5 digital inputs/outputs

→ Input / Output supply

The I/O are supplied together with the module electronics. The supply must come directly (unswitched) from the power supply unit.



Feedback may cause the destruction of the module and/or sensors!
 With the power supply switched off, connected sensors may cause feedback to take place via the output transistors. Make absolutely sure that the sensors are supplied from the same power source as the module.

→ Digital outputs, positive-switching

The digital inputs are positive-switching type 1 inputs (IEC61131-2). They are designed for nominal 24 V input voltages. The inputs are transferred internally to the core of the CPU in cycles. An open input is interpreted as static 0 (LOW).

Pulse identification and interference suppression

Inputs are read-in cyclically. The internal scanning time is fixed at 1 ms.

Principal input circuit diagram, positive-switching

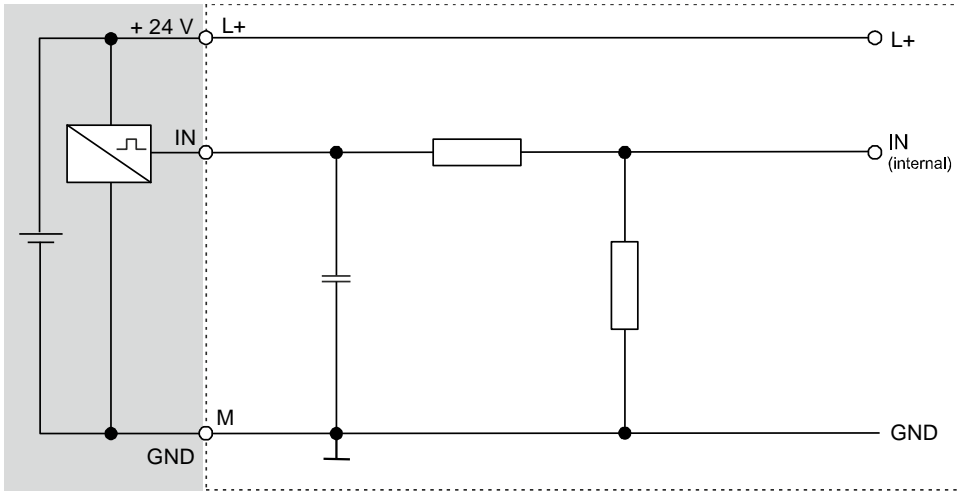

2VF100463DG00.cdr

Digital input data

Module data

Line lengths:	Connector cable < 30 m
in the switchgear cabinet	Select conductor cross-section making allowance for the voltage drop; otherwise no restrictions of practical relevance.
Field wiring	Meet all the relevant local regulations and the requirements in compliance with EN 61131-2. If there is a risk of lightning impact, please consult the manufacturer.
Load nominal voltage L+	DC 24 V (SELV)
Polarity reversal protection	Yes
Potential isolation	No
Status display	Yes, green LED per input on the plug-in connector.

→ Operating ranges of the digital inputs

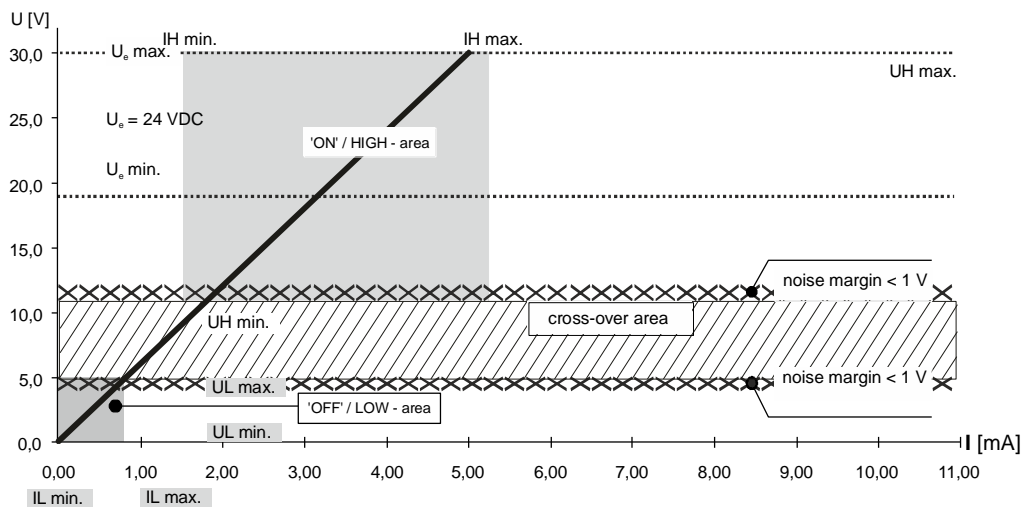

2VF100464DG01.cdr

Input voltage (DC) of extern power supply

U_e	24 V	Rated voltage
$U_e \text{ max.}$	30 V	Upper limit
$U_e \text{ min.}$	19.2 V	Lower limit

Limits for "1" signal for the "ON" condition

$U_H \text{ max.}$	30.0 V	Upper voltage limit
$I_H \text{ max.}$	5.2 mA	Upper current limit
$U_H \text{ min.}$	11.0 V	Lower voltage limit
$I_H \text{ min.}$	1.5 mA	Lower current limit

Limits for "0" signal for the "OFF" condition

$U_L \text{ max.}$	5.0 V	Upper voltage limit
$I_L \text{ max.}$	0.8 mA	Upper current limit
$U_L \text{ min.}$	0 V	Lower voltage limit
$I_L \text{ min.}$	0 mA	Lower current limit

Digital inputs with counter-encoder function

The digital inputs I9-I16 (X2) can also be used as counter / encoder inputs. Each counting unit is connected by means of two 24-V inputs. The digital status information of the inputs used as counters continues to be available to the CODESYS PLC program.

Counting units	
Number	4 counting units
Usage	Each counting unit can be used either as a quadrature decoder or upward or downward counter.
Capture input	For each counting unit a digital input can be selected which triggers capturing.
Maximum signal frequency	10 kHz (with a quadrature encoder this results in a 40 kHz counting frequency)
Minimum pulse width	50 µs
Counter width	32 bit



If overvoltage >32 V and / or energetic recovery occur, the module may be destroyed. This is a fire hazard!

→ Digital outputs, positive-switching

Outputs

The outputs are positive-switching, 24-V outputs. Output current max. 500 mA per output. The outputs have a common reference potential (GND). Power is supplied together with the supply for the module electronics (refer to ‘Terminal assignment’). If there is no data connection to the CPU or if the internal supply of the module is inadequate, the outputs automatically switch to ‘o’ (LOW).

In case of overload the current is limited (typically 3 A). After the overload has been eliminated, the output is available again. Fast de-excitation by means of a 41-V terminal voltage in relation to L+ protects all outputs against induced peak voltages with inductive loads.

If thermal loads occur owing to energetic recovery or fast de-excitation, the overload protection may react prematurely even in the case of outputs which are not involved.

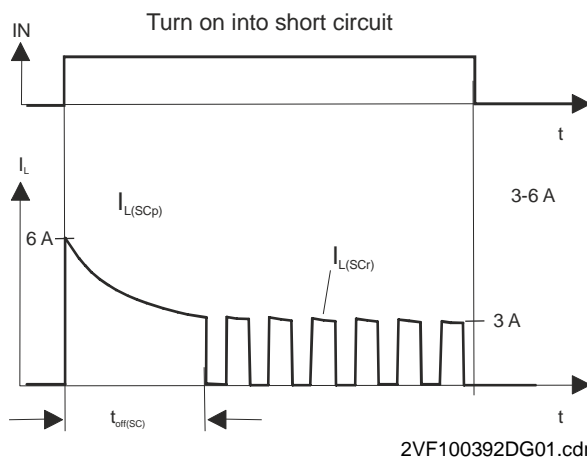

→ Protected output



The max. output current is 0.5 A.
 The output stage is protected against overload, which must be taken into account for high inrush currents from lamps, for example.

Principal output circuit diagram, positive-switching

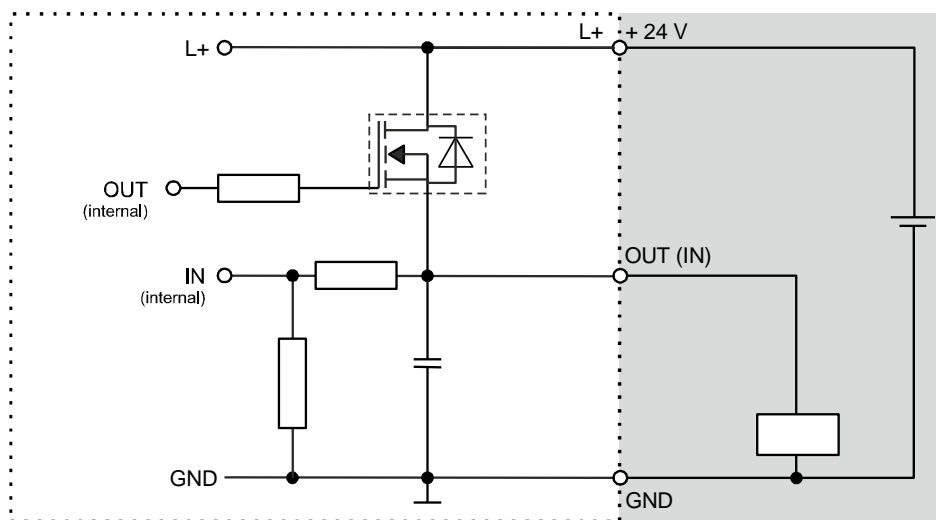

2VF100465DG00.cdr

Digital output data	
Module data	
Type of outputs	Semiconductor, non-storing
Protection circuit for inductive loads	Fast de-excitation 41 V terminal voltage (typ.) around +24 V
Power loss due to de-excitation	max. 0.5 W / output max. 4 W / module
Status display	Yes, green LED per input on the plug-in connector.
Overload protection	Yes, under thermal overload.
Short circuit protection ^{1) 2) 3)} Response threshold	Yes, electronic current limitation, typ. 3 A.
<p>1) Current is limited electronically. Triggering the short circuit protection causes thermal overload and the thermal overload protection is tripped.</p> <p>2) Starting from cold, maximally 10,000 permissible short circuits.</p> <p>3) Total duration of the short circuits max. 500 hours.</p>	
Output delay at „0“ after „1“ at „1“ after „0“	typ. 1 ms typ. 1 ms
Output capacity	< 20 nF
Rated voltage Voltage drop (with rated current)	DC +24 V < 0.1 V
Rated current with '1' signal	0.5 A
Total current of all outputs	max. 2 A
Two outputs switched in parallel for logic link for increased output	permissible permissible up to 1 A

4.5.7. Terminal assignment of digital inputs/outputs

Connection	Signal name	Configuration as Digital I/O	Counter	Note
X1	+24 V	+24 V	+24 V I/O supply	
	1	I/O1	Digital I/O +24 V	
	2	I/O2	Digital I/O +24 V	
	3	I/O3	Digital I/O +24 V	
	4	I/O4	Digital I/O +24 V	
	5	I/O5	Digital I/O +24 V	
	6	I/O6	Digital I/O +24 V	
	7	I/O7	Digital I/O +24 V	
	8	I/O8	Digital I/O +24 V	
	GND	GND	GND I/O supply	
X2	+24 V	+24 V	+24 V I/O supply	
	1	IN9	Digital IN +24 V	Counter input +24 V Encoder 1 A/up
	2	IN10	Digital IN +24 V	Counter input +24 V Encoder 1 B/down
	3	IN11	Digital IN +24 V	Counter input +24 V Encoder 2 A/up
	4	IN12	Digital IN +24 V	Counter input +24 V Encoder 2 B/down
	5	IN13	Digital IN +24 V	Counter input +24 V Encoder 3 A/up
	6	IN14	Digital IN +24 V	Counter input +24 V Encoder 3 B/down
	7	IN15	Digital IN +24 V	Counter input +24 V Encoder 4 A/up
	8	IN16	Digital IN +24 V	Counter input +24 V Encoder 4 B/down
	GND	GND	GND I/O supply	

4.5.8. Analog inputs/outputs

The module is equipped with 8 multifunctional analog channels. They are divided into 4 A channels and 4 B channels. The relevant configuration of the function is carried out via the control configuration of the CODESYS programming environment.

Functions of the A channels:

- Voltage measurement AI-U ±10 V
- Current measurement AI-I ±20 mA
- Voltage transmitter AO-U ±10 V
- Current transmitter AO-I ±20 mA

Functions of the B channels:

- Voltage measurement AI-U ±10 V

Analog channels	Connector	A	B	A	B	→ Terminal assignments
	X3	A1+ A1-	B1+ B3-	A2+ A2-	B2+ B2-	
	X4	A3+ A3-	B3+ B3-	A4+ A4-	B4+ B4-	

Voltage measurement	Connector	A	B	A	B
AI-U ±10 V	X3	AI-U	AI-U	AI-U	AI-U
	X4	AI-U	AI-U	AI-U	AI-U

Current measurement	Connector	A	B	A	B
AI-I ±20 mA	X3	AI-I	-	AI-I	-
	X4	AI-I	-	AI-I	-

Voltage transmitter	Connector	A	B	A	B
AO-U ±10 V	X3	AO-U	-	AO-U	-
	X4	AO-U	-	AO-U	-
AO-U4 ±10 V	X3	AO-U4		AO-U4	
	X4	AO-U4		AO-U4	

Current transmitter	Connector	A	B	A	B
AO-I ±20 mA	X3	AO-I	-	AO-I	-
	X4	AO-I	-	AO-I	-

→ Example

Application with 4x AO-U and 4x AI-U

Connector	A	B	A	B
X3	AO-U	AI-U	AO-U	AI-U
X4	AO-U	AI-U	AO-U	AI-U

→ Wiring information for analog channels

The high degree of measuring accuracy of the card makes specific demands on the connecting technique for the analog sensors:

- Use an analog cable with a braided shield.
- Lay the analog cable separate from the power cable. If necessary create a metallic shield in cable channels.
- Earth the shield with a clamp at the point of entry in the switch cabinet.
- Make a short connection from shield to AGND.
- Lines must be shorter than 30 m.
- Do not plug in while in operation.

Analog input parameters (AI)

General characteristics

Method of transformation	Delta-sigma transformation according to Multiplexer
Operating modes	Self-scanning
Protective equipment	
Calibration to maintain the accuracy class	12 months
Terminal arrangement	Shields on joint AGND pins or BL-I/O plug-in connectors with 3-wire connection without LED
Analog filtering	Low-pass of the 1 st order, time constant T=0.5 ms (-3 dB at 317 Hz)
Scanning time	10 μs
Scanning rate	The scanning rate of each measuring channel depends on the number of configured measuring channels.
Assignment	Mode AI-U: 1 measuring channel AI-I mode: 1 measuring channel BI-U mode: 1 measuring channel AO-U mode: 2 measuring channels AO-I mode: 1 measuring channel Unless the user additionally monitors the voltage (AI-I active).
Measuring channels	1-5 Scanning rate 1 ms 6-11 Scanning rate 2 ms 12 Scanning rate 3 ms
Filter rate and scanning rate	If the scanning rate is above 1 ms the digital filtering ensures constant value curves instead of delivering the same value repeatedly.

Analog input parameters (AI)

Digital filtering	Adjustable digital post-filtering facilitates constant signal movements. Low-pass of the 2 nd order, 1 Hz (-6 dB at 1 Hz, 10 Hz, 100 Hz or 200 Hz). Digital filtering takes place every 1 ms.
Internal data transfer	A1 and A2 transmit with 1 ms. A3-A4 and B1-B4 transmit with max. 4 ms.

Voltage input (AI-U) mode

→ applicable to all A and B channels

Connections per output	+ and -, connect shield to AGND
------------------------	---------------------------------

Static characteristics

Differential measuring range	-10...+10 V
Input impedance in the signal range	500 kΩ (between + und -)

Measuring errors

Greatest error at 25° C	±1000 ppm (±20 mV)
Temperature coefficient	±20 ppm/°K (±0.4 mV/°K)
Digital resolution	22 bit
Data format in the application program	32 bit Real (24 bit payload)
Maximum permitted continuous overload	Max. voltage on A+ or A- is ±14 V to AGND.
Digital value output during overload	If a voltage differential of 10 V is exceeded, the accuracy of this channel may be impaired; measured values are limited. If a voltage differential of 15 V is exceeded, the card reports an error which must be remedied.
Input type	Differential voltage measurement
Even range	-12 V < A+ < +12 V, -12 V < A- < +12 V
Common-mode rejection	60 dB (direct current); 20 dB at 50 Hz

Dynamic characteristics

Greatest temporary differential during electrical interference test in compliance with IEC 61131-2	1.5 % of the measuring range
--	------------------------------

Typical example of external connections

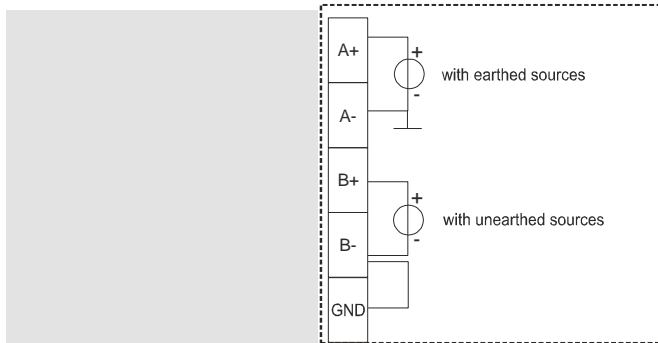

2VF100469DG02.cdr



The module is damaged at input voltages of more than ± 14 V.

→ applicable to all A channels

Current input (AI-I) mode	
Connections per output	Current between A+ and AGND, connect shield to joint AGND. Do no connect A- pin.
Static characteristics	
Measuring range	-20 mA...+20 mA; technical direction of current into A+.
Load	Typ. 110 Ω
Measuring errors	
Greatest error at 25° C	±1000 ppm (±40 µA)
Temperature coefficient	±20 ppm/°K (±0,8 µA/°K)
Digital resolution	22 bit
Data format in the application program	32 bit Real (24 bit payload)
Maximum permitted continuous overload	±24 mA If the current is continuously too great, the input is cut off. The input is briefly switched-on, for 3 ms (typ.) every 300 ms (typ). Only when the current drops below 22 mA is measurement resumed.
Digital value output during overload	In cases of overload > 22 mA, the most recent measured value is output during shutdown.
Input type	Current measurement to AGND
Reference potential	AGND
Protective equipment	Cuts off under overload
Common points between the channels	AGND reference
Dynamic characteristics (refer also to Dynamic characteristics of the analog inputs)	
Greatest temporary differential during electrical interference test in compliance with IEC 61131-2	1.5 % of the measuring range

Typical example of external connections

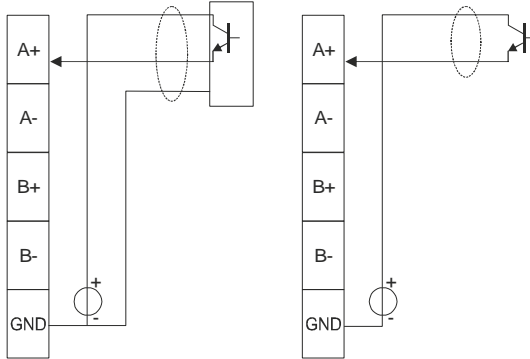

2VF100470DG00.cdr



The module is damaged at input current in excess of ± 24 mA.

Analog output parameters (AO)

General characteristics

Type of protective equipment	Electronic switch
Insulation voltage between channel and other power circuits	None

Dynamic characteristics

Settling time if there is a reversal over the full range (99.5 %)	
Filter -6 dB at 200 Hz	50 ms
Filter -6 dB at 100 Hz	50 ms
Filter -6 dB at 10 Hz	100 ms
Filter -6 dB at 1 Hz	1000 ms
Overshoot	± 5 %
Calibration to maintain the accuracy class	12 months
Greatest temporary differential during electrical interference test in compliance with IEC 61131-2	± 1.5 % of the measuring range

Voltage output (AO-U) mode

→ applicable to all A channels

Overview

Signal range	-10 V to +10 V
Connections per output	A+ and A-, connect A- to AGND. Connect shield to AGND.

Static characteristics

Output impedance in signal range	1 Ω (by readjustment)
----------------------------------	-----------------------

Analog output errors

Greatest error at 25° C	±1000 ppm (±20 mV)
Temperature coefficient	±20 ppm/°K (±0.4 mV/°K)
Value of lowest-value bit (LSB)	±15 ppm (±0.305 mV)
Digital resolution	16 bit
Data format in the application program	32 bit Real (24 bit payload)

General characteristics

Reference potential	AGND
Permissible load types	Without reference point, earthed
Greatest capacitive load	100 nF
Load impedance range	≥ 500 Ω
Overload protection	Short-circuit proof. Current limitation at around 24 mA. Interruption for 300 ms. Cyclical reattempt.

Typical example of external connections

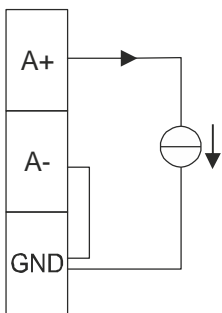

2VF100471DG00.cdr

Voltage output (AO-U) mode

Output response to On/Off switching operations of power supply

Without supply voltage	High-impedance output: A+ to AGND > 300 kΩ A- to AGND > 300 kΩ A+ to A- > 300 kΩ
During booting routine of the DC1000	The analog output is not yet active during the booting routine of the DC1000. Differences to zero value when switched on and off is around < 2 %.
If there are brief interruptions	If the supply voltage > 100 μs, the AO are briefly switched to high impedance.
Behaviour in STOP mode	Voltage output 0 V
Usage of the AI during AO operation	The current that really flows can be indicated if the analog input is configured as AI-I . The voltage between A+ and A- can be displayed if the analog input is configured as AI-U . Readjustment is not required because it is readjusted internally.

Current output (AO-I) mode

→ applicable to all A channels

Overview

Signal range	Optionally: -20 mA to +20 mA +4 mA to +20 mA
Connections per output	A+ and AGND. A- can be connected to AGND if the voltage is to be monitored. Connect shield to AGND.

Static characteristics

Output impedance in signal range	> 300 kΩ (by readjustment)
----------------------------------	----------------------------

Analog output errors

Greatest error at 25 °C	±1000 ppm (±40 μA)
Temperature coefficient	±20 ppm/°K (±0.8 μA /°K)
Value of lowest-value bit (LSB)	±15 ppm (±0.610 μA)
Digital resolution	16 bit
Data format in the application program	32 bit Real (24 bit payload)

General characteristics

Permissible load types	Load to AGND
Greatest inductive load	0.1 mH
Load impedance range	0...500 Ω

Typical example of external connections

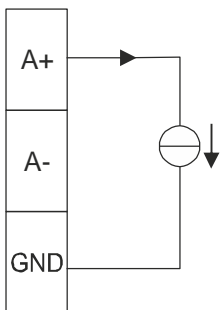

2VF100472DG00.cdr

Current output (AO-I) mode

Output response to On/Off switching operations of power supply

Without supply voltage	High-impedance output 200 kΩ at 0 V
During booting routine of the DC1000	High-impedance analog output. Brief current peaks up to 2 % may occur when switching on and switching off.
If there are brief interruptions	If the interruption > 100 μs, the AO are briefly switched to high impedance.

Behaviour in STOP mode

±20 mA	Current output: 0 mA
4 mA to 20 mA	Current output: 4 mA
Effect of defective connection to the output terminals	Withstands any overload down to no-load status, output voltage limited to ±14...18 V.
Usage of the AI during AO operation	<p>The current that really flows can be indicated if the analog input is configured as AI-I.</p> <p>The voltage between A+ and A- can be displayed if the analog input is configured as AI-U. A- must be connected to AGND for the sensor to be monitored.</p> <p>Readjustment is not required because it is readjusted internally.</p>

5. Maintenance

Maintenance tasks

Maintenance tasks on the Dialog-Controller, particularly those tasks which require opening the housing, may only be performed by qualified personnel! Before beginning any maintenance tasks, please read the chapter, “General Information”, in particular, the section, “Basic Safety Measures”.

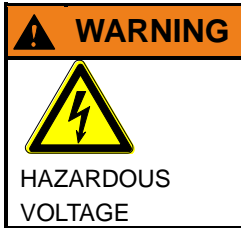

Never open housing covers with the power switched on!

Potential hazard due to contact with live components.

This can result in death, serious injury or extensive property damage.

Only open the housing cover once the Dialog-Controller has been safely disconnected from the power supply.

Maintenance work to the Dialog-Controller can result in damage:

- If metal objects such as screws, nuts, tools or other conducting objects fall on the PCB;
- If connecting cables are loosened, removed or incorrectly reconnected.

After maintenance

Before returning the Dialog-Controller to service, check to be sure that:

- There are no foreign objects in the Controller;
- There is a battery in the battery slot;
- All connections are correct and secure;
- The ground wire (PE) is properly connected.



Be sure all covers on the Dialog-Controller are closed before returning the unit to service!

5.1. Real-time clock with backup battery

The Dialog-Controller is equipped with a real-time clock.

Setting the clock

Use either the web configuration or the CODESYS “BGHSysLibRtc.lib” library.

Power supply

A battery is required to supply power to this clock.

Charge level

The Dialog-Controller monitors the backup battery’s charge level. The current battery charge state can be displayed using the CODESYS “BGHSysLibRtc.lib” library.



Backup battery voltage values which exceed 3.2 V or are below 2.0 V will affect the real-time clock’s function.
 Overvoltage: Check the battery type and device hardware.
 Undervoltage: Replace the battery.

The following battery charge levels are important:

Voltage	Battery charge level
3.2 Volt	Typical value for a new battery. This value may not be exceeded!
3.0 Volt	Nominal battery voltage
2.5 Volt	The battery should be replaced.
2.0 Volt	The battery must be replaced immediately in order to ensure the proper function of the real-time clock.



EXPLOSION HAZARD!
 Never throw batteries (new or dead) into a fire, never attempt to solder at any point on the battery case and never attempt to recharge batteries. Do not attempt to dismantle or disassemble batteries.
Replace batteries only with batteries which have the same rating!
 Make sure the battery is facing the right way when installed.

5.1.1. Battery replacement

Regardless of the indicated charge level, the backup battery must be replaced at least every five years.



Only use a CR1620 (3V lithium battery) manufactured by SONY (or an equivalent manufacturer; deviating charge current is 2.5 mA or more).
The use of any other battery may result in fire or explosion.

The real-time clock's backup battery can be replaced without the risk of data loss provided the Dialog-Controller supply voltage is switched on.



The battery is held in place by a spring clip. Never lift the spring clip retainer as this can destroy the clip!

→ [Battery replacement](#)

- Push the old battery out to the side, can be accessed from above.
- Insert the new battery from the side. Check for correct polarity and battery type.

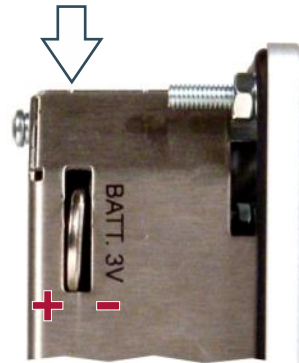

2VF100269DG03.cdr

Blank page

6. Chemical resistance

Terminals, controllers with displays and industrial PCs with displays are available in 3 versions with regard to the front foil finish (refer to section on 'Front foils'). The 3 versions also differ in respect of the materials used and their chemical resistance:

Version	Outside	Inside
Connect Touch	AUTOTEX foil	Touch foil
Connect Key	AUTOTEX foil	Glass pane
Clean Touch	AUTOFLEX foil	AUTOFLEX foil

6.1. Resistance of the touch screen

The active area of the touch screen is resistant to the following chemicals if exposed to them for a period of one hour at a temperature of 21 °C:

Industrial chemicals	Household chemicals
Acetone	Ammonia-based glass cleaners
Dichloromethane	Laundry detergent
Methyl ethyl ketone	Cleansers (Fantastic, Formula 409, Joy, etc.)
Isopropyl alcohol	Vinegar
Hexane	Coffee
Turpentine	Tea
Naphtha	Grease
Lead-free gasoline	Cooking oil
Diesel oil	Salt
Motor oil	
Transmission fluid	
Antifreeze	

6.2. Resistance of the AUTOTEX front foil sheeting to chemicals

6.2.1. General resistance of the foil sheeting material

AUTOTEX is based on a polyester foil sheet with a biaxial arrangement and therefore exhibits better resistance to solvents. It is stronger and more durable than other sheeting materials such as polycarbonate or PVC, commonly employed for touch pads and front face panels.

AUTOTEX is resistant to the following chemicals in accord. with DIN 42 115, Part 2, and will exhibit no alterations for exposure periods of more than 24 hours:

Ethanol	Formaldehyde 37 % - 42 %	I.I.I. trichloro ethane
Cyclohexanol	Acetaldehyde	Ethyl acetate
Diacetone alcohol	Aliphatic hydrocarbons	Diethyl ether
Glycol	Toluene	N-butyl acetate
Isopropanol	Xylene	Amyl acetate
Glycerin	Thinners (white spirits)	Butyl cellosolve
Methanol		Ether
Triacetin		
Dowandol DRM/PM		
Acetone	Formic acid <50 %	Sodium chloride <20 %
Methyl ethyl ketone	Acetic acid <50 %	Hydrogen peroxide <25 %
Dioxan	Phosphoric acid <30 %	Potash soap
Cyclohexanon	Hydrochloric acid <36 %	Laundry soap
MIBK	Nitric acid <10 %	Tensides
Isophoron	Trichloro acetic acid <50 %	Softeners
	Sulfuric acid <10 %	Ferric chloride (FeCl ₂)
Ammonia < 40 %	Drilling emulsions	Ferrous chloride (FeCl ₃)
Caustic soda < 40 %	Diesel oil	Dibutyl phthalate
Potassium hydroxide < 30 %	Varnish	Diocetyl phthalate
Alkali carbonate	Paraffin	Sodium carbonate
Bichromate	Castor oil	
Potassium ferrocyanide	Silicone oil	
Acetonitril	Turpentine oil replacements	
Sodium bisulfate	Brake fluid	
	Decon	
	Aircraft fuel	
	Gasoline	
	Water	
	Salt water	

AUTOTEX is resistant to glacial acetic acid in accordance with DIN 42 115, Part 2, for exposure times of < 1 hour and will exhibit no visible damage.

 <p>CAUTION</p> <p>SURFACE RESISTANCE</p>	<p>The product is not resistant to the following chemicals and impact may damage the front foil:</p> <ul style="list-style-type: none"> → Concentrated mineral acids → Concentrated alkaline solutions → Benzyl alcohol → Methyl alcohol → Iodine or Iodine solution → High pressure steam above 100 °C
--	--

6.2.2. Resistance to household chemicals

AUTOTEX is resistant to the following products and will exhibit no visible damage for exposure periods of 24 hours at 50 °C:			
Top Job	Grape juice	Ariel	Ajax
Jet Dry	Milk	Persil	Vim
Gumption	Coffee	Wisk	Domestos
Fantastic		Lenor	Vortex
Formula 409		Downey	Windex

Very close examinations would reveal mild discoloration after exposure to the following materials:

- Mustard
- Tomato juice
- Ketchup
- Lemon juice

6.2.3. Environmental values

Lowest exposure temperature

After 0.5 million activations at -40 °C, AUTOTEX exhibited no functional impairment.

Highest exposure temperature

- High humidity (> 80 % rel.H.): 40 °C
- Moderate humidity (10-80 % rel.H.): 60 °C
- Low humidity (< 10 % rel.H.): 85 °C

Outdoor use

As is the case for all polyester-based sheeting, AUTOTEX is not intended for extended exposure to direct sunlight.

6.3. Resistance of the AUTOFLEX- front foil sheeting to chemicals

6.3.1. General resistance of the foil sheeting material

AUTOFLEX is based on a polyester foil sheet with a biaxial arrangement and therefore exhibits better resistance to solvents. It is stronger and more durable than other sheeting materials such as polycarbonate or PVC, commonly employed for touch pads and front face panels.

AUTOFLEX is resistant to the following chemicals in accord. with DIN 42 115, Part 2, and will exhibit no alterations for exposure periods of more than 24 hours:

Ethanol	Acetaldehyde	Ethyl acetate
Cyclohexanol	Aliphatic hydrocarbons	Diethyl ether
Glycol	Toluene	
Isopropanol	Xylene	
Glycerin		
Methanol		
Acetone	Formic acid < 50 %	Sodium chloride < 20 %
Methyl ethyl ketone	Acetic acid < 50 %	Hydrogen peroxide < 25 %
Dioxan	Phosphoric acid < 30 %	Potash soap
	Hydrochloric acid < 10 %	Laundry soap
	Nitric acid < 10 %	Softeners
	Sulfuric acid < 10 %	
Ammonia < 2 %	Drilling emulsions	
Caustic soda < 2 %	Diesel oil	
Alkali carbonate	Varnish	
Bichromate	Paraffin	
Potassium ferrocyanide	Castor oil	
	Silicon oil	
	Turpentine oil replacements	

AUTOFLEX is resistant to glacial acetic acid in accordance with DIN 42 115, Part 2, for exposure times of < 1 hour and will exhibit no visible damage.



The product is not resistant to the following chemicals and impact may damage the front foil:

- Concentrated mineral acids
- Concentrated alkaline solutions
- Benzyl alcohol
- Methyl alcohol
- High pressure steam above 100 °C

6.3.2. Resistance to household chemicals

AUTOFLEX is resistant to the following products and will exhibit no visible damage for exposure periods of 24 hours at 50 °C:

Top Job	Grape juice	Ariel	Ajax
Jet Dry	Milk	Persil	Vim
Gumption	Coffee	Wisk	Domestos
Fantastic		Lenor	Vortex
Formula 409		Downey	Windex

Very close examinations would reveal mild discoloration after exposure to the following materials:

- Tomato juice
- Ketchup
- Lemon juice

6.3.3. Outdoor use

As is the case for all polyester-based sheeting, AUTOTEX is not intended for extended exposure to direct sunlight.

Blank page

7. Copyright and software licenses

The firmware of terminals, controllers with displays and Industrial PCs with displays contains free software. Parts of this software are subject to the following licenses:

- **GPL, refer to GPL license**
- **LGPL, refer to LGPL license**
- **MPL, refer to MPL license**
- **FTL, refer to free-type license (FTL)**

When required, the source code for the free software can be requested from Berghof within three years after delivery at cost price. The exact address for this:

Berghof Automation GmbH
Harretstrasse 1
72800 Eningen (Germany)



The licenses used by Berghof are listed in the 'Copyright and software licenses' manual.

Blank page

8. Annex

8.1. Environmental Protection

8.1.1. Emission

When used correctly, our modules do not produce any harmful emissions.

8.1.2. Disposal

At the end of their service life, modules may be returned to the manufacturer against payment of an all-inclusive charge to cover costs. The manufacturer will then arrange for the modules to be recycled.

8.2. Maintenance/Upkeep



Do not insert, apply, detach or touch connections while in operation – risk of destruction or malfunction.

Disconnect all incoming power supplies before working on our modules; this also applies to connected peripheral equipment such as externally powered sensors, programming devices, etc. All ventilation openings must always be kept free of any obstruction.

- The modules are maintenance-free when used correctly.
- Clean only with a dry, non-fluffing cloth.
- Do not use detergents!

8.3. Repairs/Service



Repair work may only be carried out by the manufacturer or its authorised service engineers.

8.3.1. Warranty

Sold under statutory warranty conditions. Warranty lapses in the event of unauthorised attempts to repair the equipment and/or product, or in the event of any other form of intervention.

8.4. Nameplate

Nameplate descriptions (example)

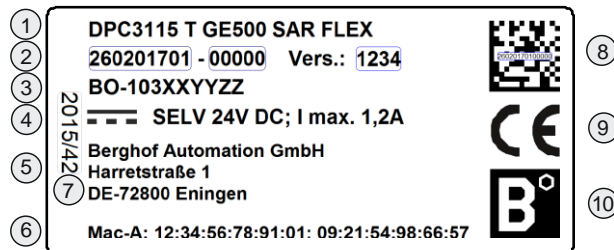

2VF100080DG03.cdr

- ① **Designation of device type**
- ② **Identification no. (item no. + serial no.)**
- ③ **Customer no.**
- ④ **Supply voltage**
- ⑤ **Manufacturer's address**
- ⑥ **Mac addresses**
- ⑦ **Production date**
- ⑧ **QR code (identification no.)**
- ⑨ **CE marking**
- ⑩ **Brand of the manufacturer (trademark)**

8.5. Addresses and Bibliography

8.5.1. Addresses

CAN in Automation; international manufacturers and users organisation for CAN users in the field of automation: → [CiA](#)

CAN in Automation e.V. (CiA)
Am Weichselgarten 26
D-91058 Erlangen / Germany
headquarters@can-cia.de
www.can-cia.de

EtherCAT Technology Group → [ETG](#)
ETG Headquarters
Ostendstraße 196
D-90482 Nuremberg / Germany
info@ethercat.org
www.ethercat.org

Beuth Verlag GmbH, 10772 Berlin → [DIN-EN Standards](#)
or
VDE-Verlag GmbH, 10625 Berlin

VDE Verlag GmbH, 10625 Berlin → [IEC Standards](#)
or
Internet search: www.iec.ch

8.5.2. Standards/Bibliography

Standard	Label
IEC61131-1 / EN61131-1	Programmable controllers Part 1: General information
IEC61131-2 / EN61131-2	Programmable controllers Part 2: Equipment requirements and tests
IEC61131-3 / EN61131-3	Programmable controllers Part 3: Programming languages
IEC61131-4 / EN61131BI1	Programmable logic controllers Supplementary Sheet 1: User guidelines
IEC61000-6-4 / EN61000-6-4	German EMC Standard: Emitted interference
IEC61000-6-2 / EN61000-6-2	German EMC Standard: Noise immunity
ISO/DIS 11898	Draft International Standard: Road vehicles - Interchange of digital information - Controller Area Network (CAN) for high-speed communication
EN 61326-1	Electrical equipment for measurement, control and laboratory use - EMC requirements Part 1: General requirements
Bibliography	A variety of specialist publications on the CANbus is available from specialist bookshops, or can be obtained through the CiA users' organisation.

Notice: Our Technical Support team will be glad to provide other literature references on request.